



CRUZ

CRUZ catalogue
LCV products

www.cruzber.com
roof racks & accessories

SINCE 1963

CRUZBER is one of the leading manufacturers of roof racks and roof bars in the European market with a complete range of solutions for passenger cars, offroad vehicles and commercial vans. Its headquarters and central warehouses are located in the province of Córdoba (Spain), with a surface area of more than 13500m². The CRUZ brand leads the Spanish market and is present in over 30 countries, developing and adapting its products to the specific needs of each market.

CRUZBER is awarded the certification of the Quality Management System based on ISO 9001:2015 for its efficiency in the operating procedures and organization. This certification is awarded to all its business processes, ranging from the development of products, manufacture, marketing and logistics to customer services.

Manufacture under strict compliance with the latest directives of the European Union, as well as certifications for specific countries. Since its foundation, quality methods and highly qualified staff constitute CRUZBER is most important, essential values. R&D: new advanced anticorrosion treatments, based on nanotechnology, guarantee exceeding 1000 hours in a saline fog chamber. The use of super durable polymers and paints with non-slip properties offer maximum resistance to harsh weather conditions. Every new product developed is tested under standard DIN 75302:2019. Ongoing adaptation and improvement of production processes to achieve more environmentally aware processes.

AN EFFICIENT, ADAPTABLE SYSTEM

CRUZBER is the main supplier of transport systems for the leading renting-leasing operators and commercial van equipment companies in the Spanish market. The CRUZ roof rack and roof bar system is made to fit most commercial vans in the market, and designed to satisfy the demands of original equipment and company fleets. At CRUZBER we adapt to our clients' specific needs, working together with our R&D department in the development and adaptation of products to their requirements. Our goal is to customise, adapt and develop products in order to offer an optimal solution to each specific need.

ROOF RACKS & ACCESSORIES

es | Portaequipajes y accesorios.

fr | Supports de toit et accessoires.

de | Dachträger und Zubehör.

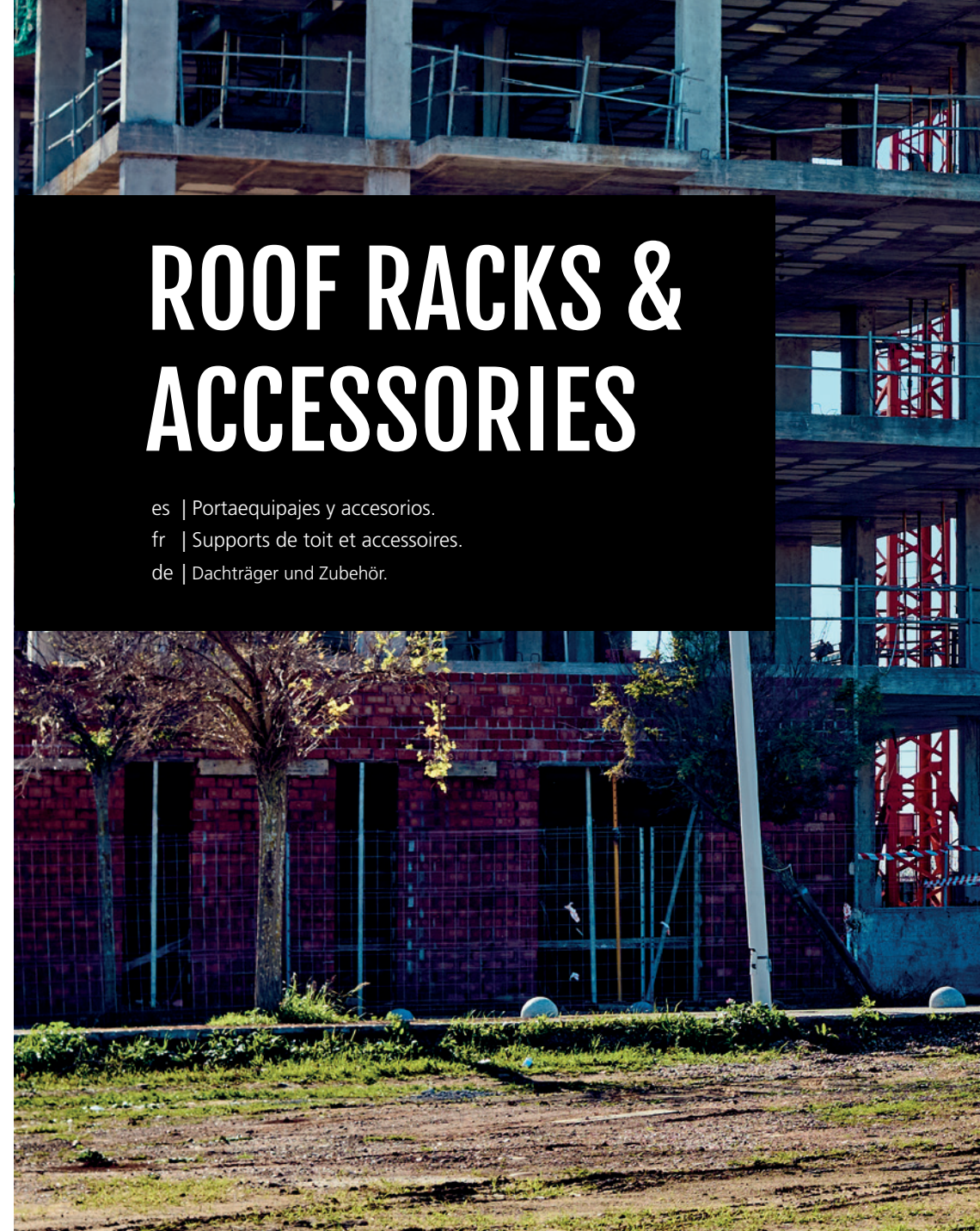





aluminium roof bars

CRUZ Alu Cargo 06
 CRUZ Alu Cargo system 08
 CRUZ Alu Cargo system accessories 09



steel roof bars

CRUZ Cargo Xpro 12
 CRUZ Cargo Xpro system 14
 CRUZ Cargo Xpro system accessories 15
 CRUZ rear door ladder type B 16
 general accessories for roof bars 17



aluminium roof racks

CRUZ Evo Rack Alu module 20
 CRUZ Evo Rack Alu system 22
 CRUZ Evo Rack Alu system accessories 23



steel roof racks

CRUZ Evo Rack Pro 24
 CRUZ Evo Rack Pro system 26
 CRUZ Evo Rack Pro system accessories 27

 CRUZ Evo Rack module 30
 CRUZ Evo Rack system 32
 CRUZ Evo Rack system accessories 33

 CRUZ Safari 34
 CRUZ Safari system 36
 CRUZ Safari system accessories 37
 CRUZ rear door ladder type EF 38
 general accessories for roof racks 39



general accessories LCV

CRUZ Ladder Clamp 40
 CRUZ Pipe Carrier 42



CRUZ info & support

other languages 44
 certifications 49
 CRUZ info & support 50



CRUZ WARRANTY

The CRUZ brand offers exceptional products with proven quality and an extended warranty against defects in material and workmanship.

- es La marca CRUZ ofrece unos productos excepcionales con una calidad probada y una garantía extendida frente a defectos de material y mano de obra.
- fr La marque CRUZ propose des produits exceptionnels avec une qualité éprouvée et une garantie prolongée contre les défauts de matériaux et de fabrication.
- de Die Marke CRUZ bietet außergewöhnliche Produkte mit bewährter Qualität und einer erweiterten Garantie gegen Material- und Verarbeitungsfehler.

	■	(code)	—	✓
en	included	optional	no available	available
es	incluido	opcional	no disponible	disponible
fr	inclus	optionnel	non disponible	disponible
de	serie	optional	nicht lieferbar	lieferbar
...	other languages □ 44			



INDEX ←



Aluminium reinforced load carrier bars. 3-slot profile.

Reinforced aluminum profile with three slots for easy mounting of accessories. Enhanced aerodynamic shape, streamlined and functional design. Maximum corrosion resistance. Ergonomy: professional safety to load the material onto the roof.

- es Barras portacargas de aluminio reforzadas. Perfil de 3 ranuras. Perfil reforzado de aluminio con tres ranuras para fácil acoplamiento de accesorios. Excelente aerodinámica y diseño elegante y funcional. Mayor resistencia y protección anticorrosiva. Ergonomía: seguridad profesional para la carga del material sobre el techo.
- fr Barres porte tout en aluminium renforcé. Profil de 3 fentes. Profil renforcé en aluminium avec 3 fentes pour installer très facilement des accessoires. Excellent aérodynamique et design élégant et fonctionnel. Résistance et protection anticorrosive supérieures. Ergonomie: sécurité professionnelle pour la charge du matériel sur le toit.
- de Verstärkte Aluminium-Dachträger. Dreikanalprofil. Verstärktes Aluminium-Dreikanalprofil zur leichten Montage von Zubehör. Ausgezeichnete Aerodynamik mit attraktivem funktionellem Design. Sehr robust und höchster Korrosionsschutz. Ergonomie: professionelles Sicherheitsniveau zur Ladung von Material auf dem Fahrzeugdach.
- ... **other languages** 44

924-xxx	CRUZ Alu Cargo X/T	■ —	52x35	1180-1330	□	■	—	■	B-F-C	75	932-01x
925-xxx	CRUZ Alu Cargo Dark X/T	— ■	52x35	1180-1330	□	■	—	■	B-F-C	75	932-01x
924-x6x	CRUZ Alu Cargo R	■ —	52x35	1280-1480	■	■	—	—	R	75	—
924-x9x	CRUZ Alu Cargo AF	■ —	52x35	1180-1580	■	■	■	933-xxx / 934-xxx	B-F-C-V	150	932-01x
925-xxx	CRUZ Alu Cargo Dark AF	— ■	52x35	1180-1580	■	■	■	933-xxx / 934-xxx	B-F-C-V	150	932-01x

¹ mm, ² 8, ³ kg * total years (product registration needed)

- Aluminium 6063/T6
- Matt anodized

- ⚙️ - Pickling steel
- Oxsilan
- HQ Polymer class 2

- silver aluminium
- black aluminium

3 years warranty
años de garantía
ans de garantie
jahre garantie *

-
- ⚙️ - CRUZ Alu Cargo AF
- CRUZ Kit LCV
- CRUZ loading roller supports

INDEX ←

CRUZ Alu Cargo



CRASH TEST (↔)

DIN 75302:2019
ISO/PAS 11154:2006

ECE R26

low profile supports
aerodynamic design
3-slot profile



INDEX ←

CRUZ Alu Cargo



- silver aluminium
- black aluminium



CRUZ Alu Cargo X/T
CRUZ Kit Optiplus



CRUZ Alu Cargo R

CRUZ Alu Cargo AF



- silver aluminium
- black aluminium



CRUZ Alu Cargo AF
CRUZ Kit LCV



CRUZ Alu Cargo AF
CRUZ Kit V



CRUZ Alu Cargo AF

roof types



CRUZ Alu Cargo AF, CRUZ Kit LCV



CRUZ Alu Cargo T



CRUZ Alu Cargo R



CRUZ Alu Cargo AF, CRUZ Kit V

CRUZ Alu Cargo system accessories

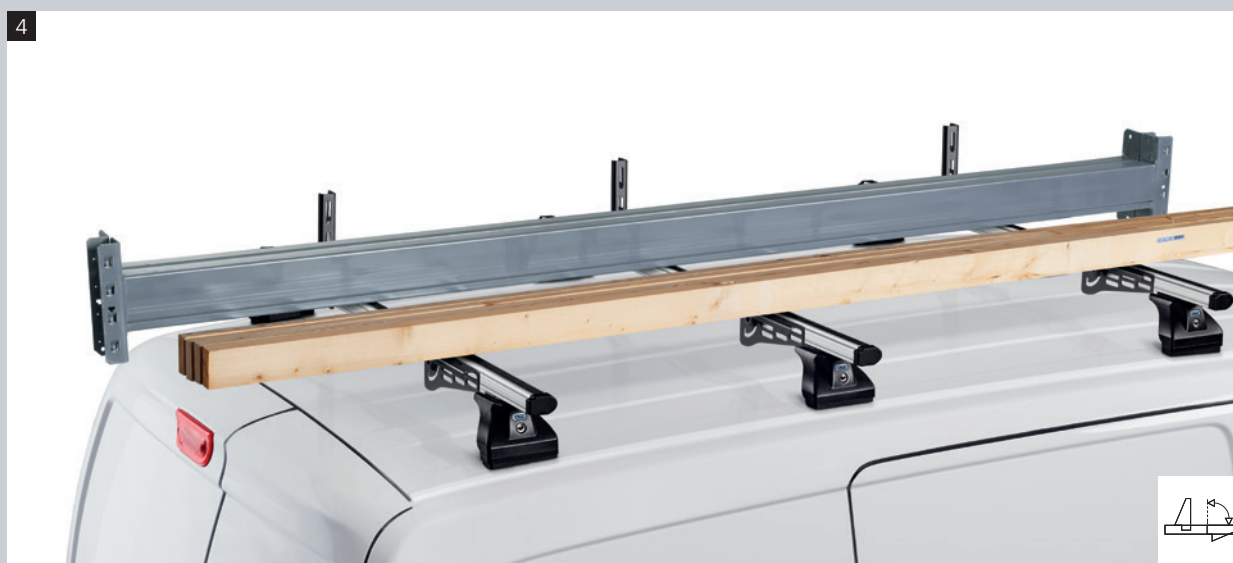

1	932-01x	CRUZ anti-theft key locks
2	941-310	CRUZ M8 eye bolts
3	932-050	CRUZ anti-theft end caps 52x35
4	941-4xx	CRUZ foldable load stops Alu Cargo

SAFE SYSTEMS FOR LOADING AND TRANSPORTING MATERIALS ON THE ROOF OF THE VEHICLE. ↘

es | Sistemas seguros para la carga y transporte de material sobre el techo del vehículo.

fr | Système sécurisé pour la charge et transport du matériel sur le toit du véhicule.

de | Sichere Systeme zum Laden und Transportieren von Materialien auf dem Fahrzeugdach.



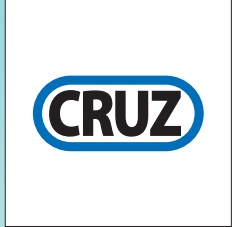

INDEX ←













CRUZ Cargo Xpro SF
CRUZ Kit LCV



Heavy-Duty roof bars with galvanized steel aerodynamic profile for light commercial vehicles.

The CRUZ Cargo Xpro roof bars have an aerodynamic profile with an oval section made of galvanized steel, in line with the aesthetics of current vehicle models.

- es Barras de techo reforzadas con perfil aerodinámico de acero galvanizado para vehículos comerciales ligeros. Las barras de techo CRUZ Cargo Xpro tienen un perfil aerodinámico de sección oval de acero galvanizado, en línea con la estética de los modelos de vehículos actuales.
- fr Barres de toit robustes avec profil aérodynamique en acier galvanisé pour véhicules utilitaires légers. Les barres de toit CRUZ Cargo Xpro ont un profil aérodynamique avec une section ovale en acier galvanisé, en ligne avec l'esthétique des modèles de véhicules actuels.
- de Heavy-Duty Stahl-Dachträger mit aerodynamischem Profil aus verzinktem Stahl für leichte Nutzfahrzeuge. Der CRUZ Cargo Xpro Dachträger hat ein aerodynamisches Profil mit ovalem Querschnitt aus verzinktem Stahl, der mit der Ästhetik aktueller Fahrzeugmodelle verbindet.
- ... **other languages** ▢ 44

										
923-xxx	CRUZ Cargo Xpro 2022 SF	50x30x1.5	1150-1600	□ ■ ■	933-xxx / 934-xxx	B-F-C	150	932-0xx		
							* total years (product registration needed)			

-  - Galvanized steel Z275
-  - Cover LDPE

-  - Pickling steel
-  - Oxsilan
-  - HQ Polymer class 2

3 years warranty
años de garantía
ans de garantie
jahre garantie *

-
-  - CRUZ Cargo Xpro 2022 SF
- CRUZ Kit LCV
- CRUZ load stops
- CRUZ straps

new

CRUZ Cargo Xpro



CRASH TEST (↔)

DIN 75302:2019
ISO/PAS 11154:2006

ECE R26

Heavy-Duty aerodynamic profile



INDEX ←



CRUZ Cargo Xpro system



roof types

F C B

CRUZ Cargo Xpro SF, CRUZ Kit LCV





CRUZ Cargo Xpro system accessories

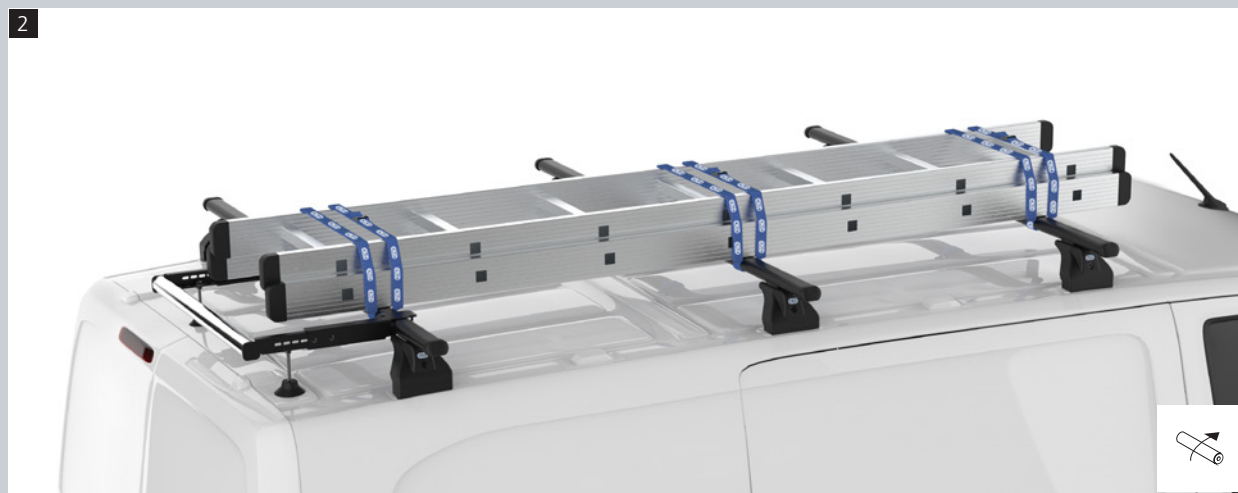

- 1 941-02x CRUZ load stops CRUZ Cargo Xpro
- 2 941-44x CRUZ loading roller supports

INDEX ←



textured finish
DIN-Norm 51130
Anti-slip R11



CRUZ rear door ladder type B

3 years warranty
años de garantía
ans de garantie
Jahre garantie *

DIN 51130
Anti-slip R11

Access ladder for the rear door

Ladder to access the roof rack and to be fitted on the rear door of the van. Suitable to all types of doors, not being necessary to drill the vehicle. It is possible to fit on vans with windows on the rear doors. This ladder is more rigid thanks to larger tubes. Textured anti-slip finish. It meets anti-slip standards DIN 51130; Anti-slip R11. Necessary to assemble the CRUZ Kit rear door ladder specific to each vehicle. Not suitable for vans with tailgate.

- es Escalera de acceso para la puerta trasera. Escalera para acceder al portaequipajes del vehículo de colocación sobre la puerta trasera de la furgoneta. Adaptable a todo tipo de puertas sin necesidad de realizar perforaciones. Posibilidad de colocación incluso en furgonetas con puerta trasera acristalada. Mayor rigidez gracias a los tubos de mayor sección. Acabado en pintura rugosa anti-deslizamiento. Cumple normativa anti-deslizamiento DIN 51130; Anti-slip R11. Necesario para su montaje el CRUZ Kit rear door ladder específico para cada vehículo. No compatible con portón trasero.
- fr Échelle porte-arrière. Compatible avec tout type de portes, sans perforation. Il est possible d'installer sur les portes vitrées. Plus de rigidité, grâce à la construction en tubes de section majeur. Revêtement en peinture antidérapante. Accomplissement de la Norme Anti Derapante DIN 51130; Anti-slip R11.Échelle porte-arrière. Échelle pour accéder à la galerie, d'installation sur la porte-arrière du véhicule. Compatible avec tout type de portes, sans perforation. Il est possible d'installer sur les portes vitrées. Plus de rigidité, grâce à la construction en tubes de section majeur. Revêtement en peinture antidérapante. Accomplissement de la Norme Anti Derapante DIN 51130; Anti-slip R11. Indispensable le CRUZ Kit rear door ladder spécifique à chaque véhicule. Pas compatible avec des véhicules avec hayon.
- de Hecktürleiter. Hecktürleiter für den sicheren Aufstieg zum Gepäckträger des Nutzfahrzeugs. Kompatibel mit allen Heckflügeltüren, ohne Bohren. Montagemöglichkeit auch an Nutzfahrzeugen mit Heckfenster. Höhere Steifigkeit durch ein größeres Schnittprofil. Oberflächenbeschaffenheit: Anti-Rutsch schwarz strukturiert. Die Leiter erfüllt die DIN-Norm 51130; Klasse der Rutschhemmung R11. Für die Montage wird das für jedes Fahrzeug spezifische CRUZ Kit Rear Door Ladder benötigt. Nicht kompatibel mit Heckklappen.

... other languages 44

		¹	Max: ²		
941-072	CRUZ rear door ladder type B 155	1550	100	✓	— ³
941-074	CRUZ rear door ladder type B 185	1850	100	✓	— ³
941-076	CRUZ rear door ladder type B 208	2080	100	✓	— ³

¹ mm, ² kg, ³ not suitable for vans with tailgate

* total years (product registration needed)

- Pickling steel
- Oxsilan
- HQ Polymer class 2

←

- CRUZ rear door ladder type B

general accessories for roof bars



- 1 941-02x CRUZ load stops
- 2 941-447 CRUZ loading roller supports Xpro
- 3 941-44x CRUZ loading roller support

DESIGNED TO MEET THE NEEDS OF PROFESSIONAL USERS ↘

es | Diseñados para satisfacer las necesidades del usuario profesional

fr | Développés pour satisfaire les besoins des professionnels

de | Entwickelt, um die Bedürfnisse professioneller Anwender zu erfüllen



CRUZ



INDEX ←



- better aerodynamics thanks to the new wind deflector



Ergonomic roof rack made of matt anodized aluminium

Roof rack exclusively made of aluminium, with a compact, robust and ergonomic design. Innovative system which allows a quick fitting of crossbars, now made of aluminium, with an aerodynamic design and t-tracks in the back to fit accessories. Lateral profiles with two longitudinal slots ensuring a greater flexibility to fit all models of vehicles.

- es Portaequipajes ergonómico fabricado en aluminio anodizado mate. Portaequipajes fabricado completamente en aluminio con diseño compacto, robusto y ergonómico. Innovador sistema de fijación rápida de los tubos de parrilla, ahora en aluminio, con diseño aerodinámico y carril posterior para el acoplamiento de accesorios. Perfiles laterales con doble ranura para una mayor flexibilidad y ajuste a cada modelo de vehículo.
- fr Galerie ergonomique fabriquée entièrement en aluminium anodisé mat. Galerie fabriquée entièrement en aluminium, avec un design compact, robuste et ergonomique. Novateur système de fixation rapide des tubes transversaux en aluminium, avec design aérodynamique et profil postérieur pour y installer des accessoires. Profils latéraux avec double fente pour plus de flexibilité et adaptation à chaque modèle de véhicule.
- de Ergonomischer Dachgepäckträger aus matt eloxiertem Aluminium. Aluminium-Dachgepäckträger mit kompaktem, robustem und ergonomischem Design. Innovatives Einschleiben der Aluminium-Traversen am inneren Trägerkanal der neuen Seitenrahmenprofile des Dachgepäckträgers, mit aerodynamischem Design und einem auf der Rückseite befindlichem Kanal zur leichten Montage von Zubehör. 2-Kanal Seitenrahmenprofile für höhere Flexibilität und Anpassung an jeden Fahrzeugtyp.

... other languages 44

		L ¹	W ¹	Kit	Max: Kit type ²	roof type ³					
912-xxx	CRUZ Evo Rack Alu module	1300-4800	1100-1700	933-xxx 934-xxx	180	B-F-C V	■	■	932-01x	✓	✓
¹ mm, ² kg, ³ □ 22							* total years (product registration needed)				

- Aluminium 6063/T6
- Matt anodized

3 years warranty
años de garantía
ans de garantie
jahre garantie *

- Pickling steel
- Oxsilan
- HQ Polymer class 2

- - CRUZ Evo Rack Alu module
- CRUZ Kit LCV

INDEX ←

CRUZ Evo Rack Alu module



CRASH TEST ↗

DIN 75302:2019
ISO/PAS 11154:2006

ECE R26

exclusively made of aluminium



INDEX ←

CRUZ Evo Rack Alu system

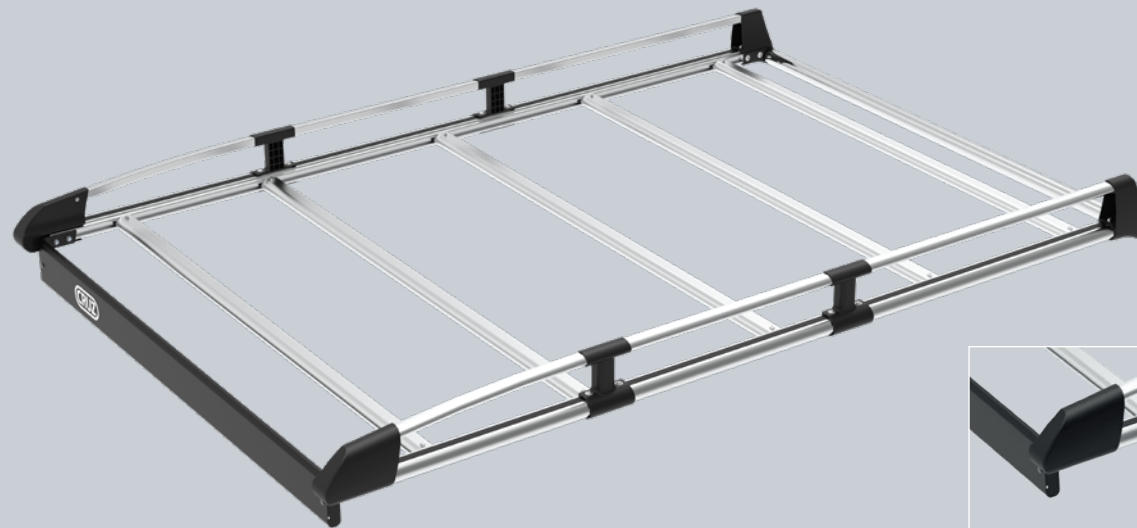
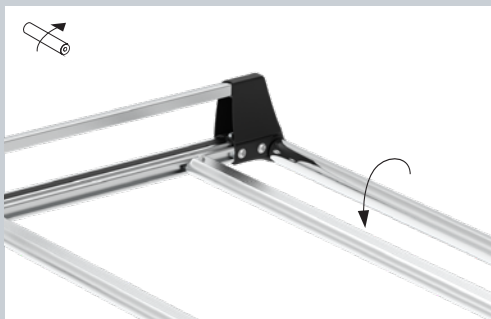
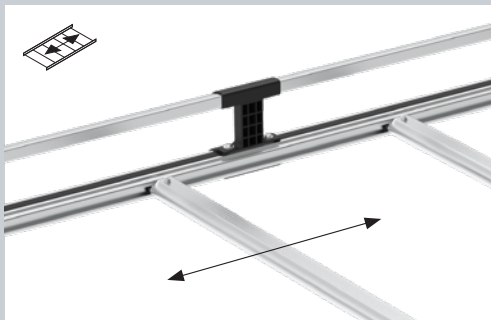
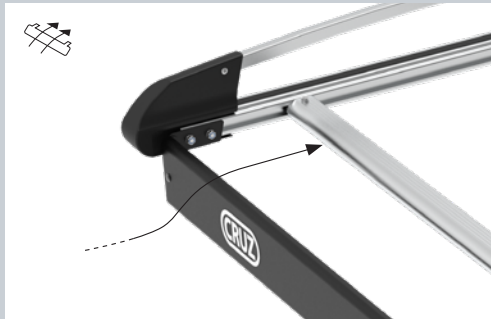

CRUZ Evo Rack Alu module
CRUZ Kit LCV

roof types

F C B V



CRUZ Evo Rack Alu system accessories



- | | | |
|---|---------|------------------------------|
| 1 | 941-00x | CRUZ load stops Evo Rack Alu |
| 2 | 941-5xx | CRUZ walkway Evo Rack Alu |

INDEX ←

Specially robust and ergonomic roof racks made of galvanized steel

Great strength of its structure thanks to the fact that it has been especially designed for all models of vehicles and larger dimensions. Higher resistance to extreme weather conditions because it is made of galvanized steel. Better aerodynamics thanks to a new wind deflector. Higher side rails, guaranteeing a greater security of the load carried.

- es Portaequipajes de acero galvanizado extremadamente robusto y ergonómico. Gran rigidez estructural gracias a que han sido diseñados específicamente para cada modelo de vehículo y contar con perfiles de mayor sección. Mayor resistencia a condiciones climáticas extremas gracias a estar fabricados en acero galvanizado. Mejor aerodinámica gracias al nuevo deflector. Barandillas laterales de mayor altura, lo que garantiza una mayor seguridad de la carga transportada.
- fr Galerie en acier galvanisé extrêmement robuste et ergonomique. Structure plus rigide grâce aux profils plus larges et le redimensionnement complet des galeries adaptées à chaque modèle de véhicule. Plus résistant aux conditions climatiques sévères grâce à l'acier galvanisé. Aérodynamique améliorée grâce au design de la galerie et le nouveau déflecteur. Rampes latérales plus élevées, ce qui permet de mieux sécuriser la charge.
- de Verzinkter Stahl-Dachgepäckträger extrem robust und ergonomisch. Die robuste Struktur – jetzt mit größerem Schnittprofil – ist speziell für jedes Fahrzeugmodell konstruiert. Hergestellt aus verzinktem Stahl, für erhöhte Beständigkeit und als Schutz gegen extreme Wetterbedingungen. Bessere Aerodynamik durch serienmäßigen Frontspoiler. Höhere Seitenrahmenprofile, um eine größere Sicherheit der Ladung zu garantieren.

... other languages □44

-  - Galvanized steel
- Oxsilan
- HQ Polymer class 2

-  - Pickling steel



913-xxx	CRUZ Evo Rack Pro	1800–4400	1100–1700	■	180	B–F–C	■	■	932-01x	✓	— ⁴
<small>¹ mm, ² kg, ³ □ 26, ⁴ not available for V-type kit</small>											

* total years (product registration needed)



3 years warranty
años de garantía
ans de garantie
jahre garantie *



INDEX ←

CRUZ Evo Rack Pro



CRASH TEST (↔)

DIN 75302:2019
ISO/PAS 11154:2006

ECE R26

especially robust & ergonomic



INDEX ←

CRUZ Evo Rack Pro system

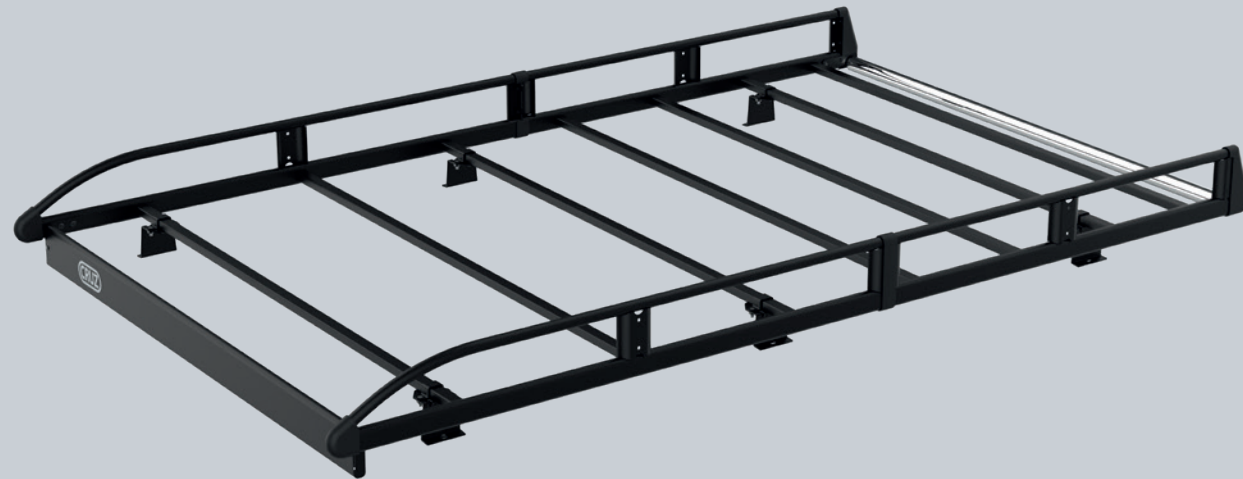

roof types

F C B



CRUZ Evo Rack Pro system accessories



- | | | |
|---|---------|--|
| 1 | 941-44x | CRUZ half roller supports (right) Evo Rack Pro |
| 2 | 941-44x | CRUZ half roller supports (left) Evo Rack Pro |

FOR THE DAY BY DAY OF PROFESSIONALS ↘

es | Para el día a día del profesional

fr | Pour aider les travailleurs

de | Für den Berufsalltag



CRUZ



INDEX ←



- new design which provides a greater rigidity



Galvanized steel roof rack with a compact, robust and an ergonomic design

Higher resistance to extreme weather conditions as it is made of galvanized steel. Robust structure with a new design which provides a greater rigidity to the set. Innovative quick fitting system of the crossbars of the roof racks; these crossbars, together with the new design of the side tubes with open inner rails, improve the assembly time. The dimensions have been fully redesigned so that it can adapt better to each type of vehicle.

- es Portaequipajes de acero galvanizado con diseño compacto, robusto y ergonómico. Mayor resistencia a duras condiciones climáticas gracias a estar fabricado en acero galvanizado. Robusta estructura con nuevo diseño que confiere una mayor rigidez al conjunto. Innovador sistema de fijación rápida de los tubos parrilla que, unidos al nuevo diseño de tubos laterales con carril interior continuo, mejoran el tiempo de montaje. Completo rediseño de medidas para mejor adaptación a cada modelo de vehículo.
- fr Galerie en acier galvanisé avec un design compact, robuste et ergonomique. Plus résistant aux conditions climatiques sévères grâce à l'acier galvanisé. Structure plus robuste avec un nouveau design lequel offre plus rigidité à la galerie. Système novateur de fixation rapide des tubes transversaux qui avec le nouveau design des tubes longitudinaux disposant de profil intérieur continu, permettent de réduire le temps d'installation. Esthétique améliorée par rapport aux modèles précédents, plus proche aux modèles de véhicules actuels, avec finition de peinture texturisée.
- de Verzinkter Stahl-Dachgepäckträger mit kompaktem, robustem und ergonomischem Design. Hergestellt aus verzinktem Stahl, für erhöhte Beständigkeit und als Schutz gegen extreme Wetterbedingungen. Eine robuste Struktur mit neuem Design garantiert eine höhere Verwindungssteifigkeit. Geringe Montagezeit durch innovatives Einschleiben der Vierkantraversen am inneren Trägerkanal der neuen Seitenrahmenprofile des Dachgepäckträgers. Die neuen Abmessungen des Dachgepäckträgersystems passen perfekt zu jeden Fahrzeugtyp.
- ... other languages 44

		L ¹	W ¹	Kit	Max: Kit type ²	roof type ³					
910-xxx	CRUZ Evo Rack module	1300–4800	1100–1700	933-xxx 934-xxx	180	B-F-C V	<input checked="" type="checkbox"/>	<input type="checkbox"/>	932-01x	<input checked="" type="checkbox"/>	<input checked="" type="checkbox"/>
¹ mm, ² kg, ³ <input type="checkbox"/> 32, ⁴ not available for V-type kit							* total years (product registration needed)				

- Galvanized steel
- Oxsilan
- HQ Polymer class 2

3 years warranty
años de garantía
ans de garantie
jahre garantie *

- Pickling steel
- Oxsilan
- HQ Polymer class 2

-
- CRUZ Evo Rack module
 - CRUZ Kit LCV
 - CRUZ roller

CRUZ Evo Rack module



CRASH TEST (↔)

DIN 75302:2019
ISO/PAS 11154:2006

ECE R26

compact, robust and an ergonomic



INDEX ←

CRUZ Evo Rack module system

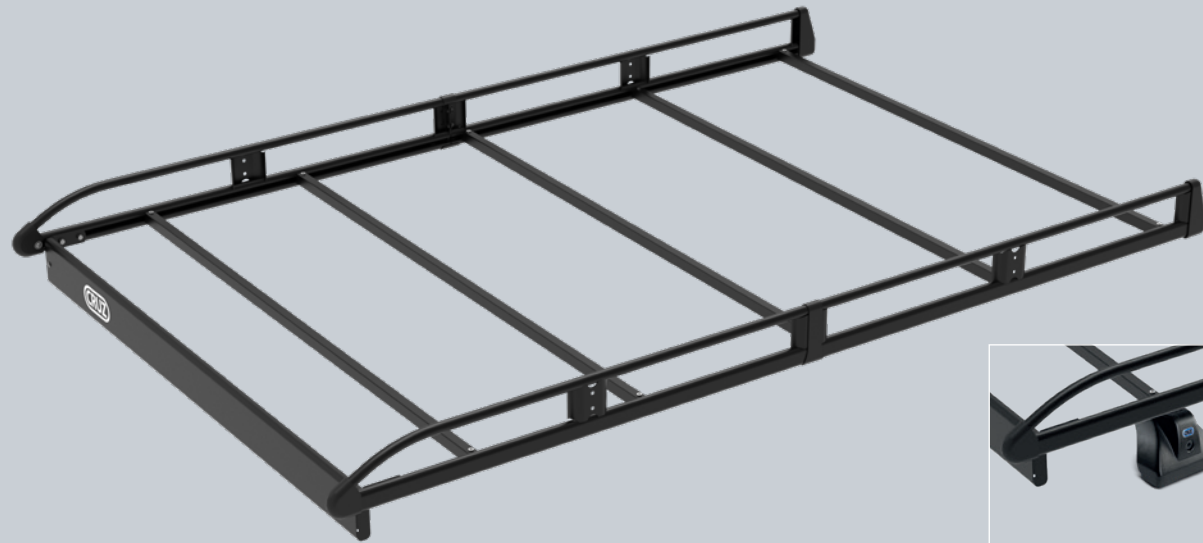
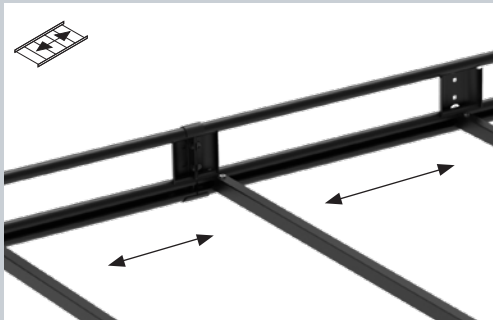

CRUZ Evo Rack module
CRUZ Kit LCV

roof types

F C B V



CRUZ Evo Rack module system accessories



1	932-01x	CRUZ anti-theft locks
2	941-00x	CRUZ load stops Evo Rack
3	941-1xx	CRUZ roller Evo Rack
4	941-430	CRUZ walkway Evo Rack
5	941-44x	CRUZ half roller supports (left) Evo Rack
6	941-44x	CRUZ half roller supports (right) Evo Rack

INDEX ←



- specially designed for 4x4 vehicles



Roof rack module specially designed for 4x4 vehicles

The CRUZ Safari roof rack module is strong and long-lasting, with a large load capacity. Its design includes rails all around its perimeter and an integrated deflector for a better aerodynamics and safety. Wide variety of specific accessories, compatible with all steel CRUZ roof racks and designed to meet the needs of the user of 4x4 vehicles.

- es Módulo portaequipajes especialmente diseñado para vehículos 4x4. El módulo CRUZ Safari es un portaequipajes robusto, duradero y con gran capacidad de carga. Su diseño incluye barandillas por todo su perímetro y un deflector integrado de serie para una mejor aerodinámica y seguridad. Gran variedad de accesorios específicos, compatibles con resto de portaequipajes CRUZ de acero, y diseñados para satisfacer las necesidades del usuario de vehículos 4x4.
- fr Galerie modulaire spécifiquement conçue pour les véhicules 4x4. La galerie modulaire CRUZ Safari est robuste et durable, avec une grande capacité de charge. Son design inclut des rails autour de son périmètre et un déflecteur intégré pour une meilleure aérodynamique et sécurité. Grande variété d'accessoires spécifiques compatibles avec le reste des galeries CRUZ en acier, conçus pour répondre aux besoins des usagers des véhicules 4x4.
- de Gepäckträgermodul speziell konzipiert für Allrad-Fahrzeuge. Das Modul CRUZ Safari ist ein robuster, haltbarer Gepäckträger mit großer Nutzlast. Zum Design gehören rundum verlaufende Geländer und ein serienmäßig integrierter Deflektor für bessere Aerodynamik und mehr Sicherheit. Große Auswahl an Spezialzubehör, das mit den übrigen CRUZ Stahl-Gepäckträgern kompatibel ist und den Bedürfnissen der Nutzer von Geländefahrzeuge gerecht wird.
- ... **other languages** □44

		L ¹	W ¹	Kit	Max: Kit type ²	roof type ³			
901-9xx	CRUZ Safari	1325-2625	1100-1400	933-xxx	180	V	■	✓	✓
		¹ mm, ² kg, ³ □ 36		* total years (product registration needed)					

- Galvanized steel
- Oxsilan
- HQ Polymer class 2

- Pickling steel
- Oxsilan
- HQ Polymer class 2

3 years warranty
años de garantía
ans de garantie
jahre garantie *

-
- CRUZ Safari
 - CRUZ Kit V
 - CRUZ load stops
 - CRUZ foldable ladder

INDEX ←

CRUZ Safari



CRASH TEST (↔)

DIN 75302:2019
ISO/PAS 11154:2006

ECE R26

specifically designed
for 4x4 vehicles



INDEX ←



roof types

- 📷 - CRUZ Safari
- CRUZ Kit V

V



- 📷 - CRUZ Safari
- CRUZ Alu Cargo X /T

F C B R



CRUZ Safari system accessories



1	941-05x	CRUZ foldable ladder
2	941-26x	CRUZ walkway
3	941-00x	CRUZ load stops



INDEX ←



CRUZ rear door ladder type EF

3 years warranty
años de garantía
ans de garantie
jahre garantie *

DIN 51130
Anti-slip R11

Rear door fixed ladder

Fixed ladder to access the roof rack, assembled on the rear door of commercial vehicles. Textured anti-slip finish. It meets anti-slip standards DIN 51130; Anti-slip R-11. Compatible only with vehicles without rear glass window. Not suitable for vans with tailgate.

- es Escalera fija de acceso para la puerta trasera. Escalera fija para acceder al portaequipajes del vehículo de colocación sobre la puerta trasera de la furgoneta. Acabado en pintura rugosa anti-deslizamiento. Cumple normativa anti-deslizamiento DIN 51130; Anti-slip R-11. Compatible únicamente con vehículos sin puerta trasera acristalada. No compatible con portón trasero.
- fr Échelle fixe d'accès pour la porte arrière. Échelle fixe d'accès à la galerie montée sur la porte arrière des véhicules utilitaires. Revêtement en peinture antidérapante. Accomplissement de la Norme Anti Derapante DIN 51130; Anti-slip R-11 Compatible uniquement avec les véhicules sans porte arrière vitrée. Pas compatible avec les véhicules avec hayon..
- de Feste Hecktürleiter. Feste Leiter für den Zugang zum Gepäckträger am Fahrzeug mit Anbringung an der Hecktür des Lieferwagens. Oberflächenbeschaffenheit: Anti-Rutsch schwarz strukturiert. Die Leiter erfüllt die DIN-Norm 51130; Klasse der Rutschhemmung R11. Nur kompatibel mit Fahrzeugen ohne Hecktür mit Fensterscheiben. Nicht kompatibel mit Heckklappe.

... **other languages** 44

		¹	Max: ²		
941-060	CRUZ rear door ladder type EF 120	1200	100	✓	— ³
941-062	CRUZ rear door ladder type EF 150	1500	100	✓	— ³
941-064	CRUZ rear door ladder type EF 180	1800	100	✓	— ³

¹ mm, ² kg, ³ not suitable for vans with tailgate

* total years (product registration needed)

- Pickling steel
- Oxsilan
- HQ Polymer class 2

- ←
- CRUZ Evo Rack Alu
- CRUZ rear door ladder type EF
- CRUZ straps

general accessories for roof racks

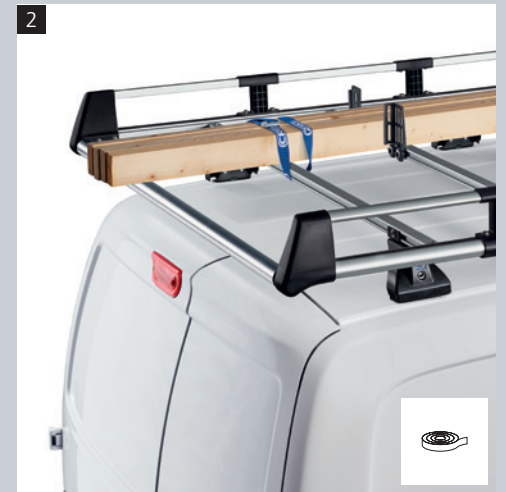

- | | | |
|---|---------|--------------------------------|
| 1 | 941-04x | CRUZ ladder clamps |
| 2 | 941-30x | CRUZ straps |
| 3 | 941-30x | CRUZ ratchet straps |
| 4 | 941-304 | CRUZ ratchet strap with S hook |
| 5 | 941-07x | CRUZ rear door ladder type B |

INDEX ←

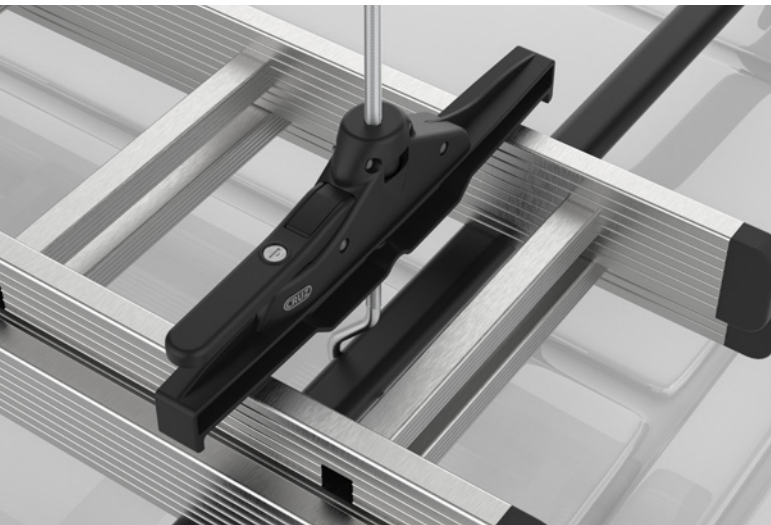

Innovative ladders fitting system with an elegant, ergonomic design and quick assembly

The design of the CRUZ Ladder Clamp's fittings have been specially conceived to ensure that the professional user's experience when loading and transporting ladders is easy, fast, safe and ergonomic. In this way, the professional users can, therefor, spend their time on what really matters.

- es Innovador sistema de fijación para escaleras con diseño elegante, ergonómico y de montaje rápido. El diseño de las fijaciones para escaleras CRUZ Ladder Clamp ha sido especialmente concebido para garantizar que la experiencia del usuario profesional al cargar y transportar escaleras sea fácil, rápida, segura y ergonómica. De esta forma, los usuarios profesionales pueden destinar su tiempo a lo realmente importante.
- fr Système innovant de fixation d'échelles avec un design élégant et ergonomique et un montage rapide. Le design des fixations des échelles CRUZ Ladder Clamp a été spécialement conçu pour que l'utilisateur professionnel puisse charger et transporter les échelles de manière simple, rapide, sûre et ergonomique. De cette manière, il pourra consacrer son temps à ce qui compte vraiment.
- de Innovatives Befestigungssystem für Leitern mit einem eleganten, ergonomischen Design und schneller Montage. Das Design der CRUZ Ladder Clamp-Befestigungen für Leitern wurde speziell entwickelt, um das Tragen und Transportieren von Leitern für den professionellen Benutzer einfach, schnell, sicher und ergonomisch zu machen. Dadurch können professionelle Benutzer ihre Zeit dem widmen, was wirklich wichtig ist.
- ... **other languages** **44**

		¹	Max: Kit type ²	²	
941-043	CRUZ Ladder Clamp	457x47x427	40	2,10	■
¹ mm (LxWxH), ² kg			* total years (product registration needed)		



- two units included

3 years warranty
años de garantía
ans de garantie
jahre garantie *

-
- CRUZ Evo Rack module
 - CRUZ Kit LCV
 - CRUZ roller
 - CRUZ Ladder Clamp

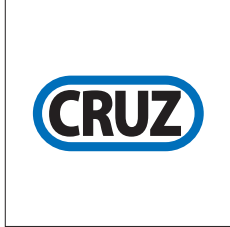

INDEX ←

new

CRUZ Ladder Clamp



pending



pending



pending



pending

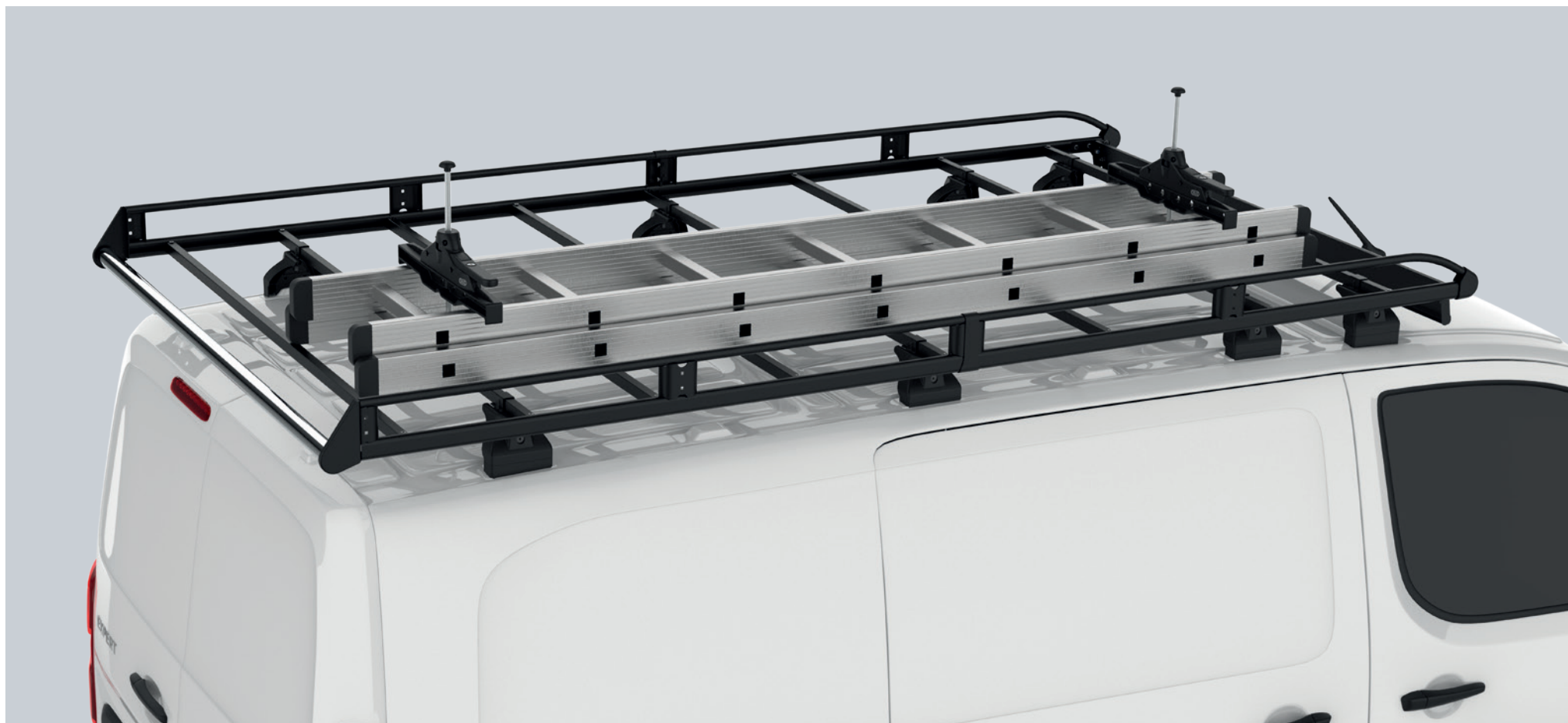

INDEX ←



Accessory for transporting pipes safely on the roof of the light commercial vehicle.

CRUZ Pipe Carrier has been specially designed for professionals to safely and ergonomically transport on their vehicle copper and other material pipes, as well as plastic conduit and other types of long materials. The pipe carrier can be opened at both ends to facilitate loading and unloading of the material. The lockable end caps have an integrated security system to prevent theft of the transported material.

- es Accesorio para el transporte de tubos de forma segura en el techo del vehículo comercial ligero. CRUZ Pipe Carrier ha sido especialmente diseñado para que el profesional transporte sobre su vehículo tuberías de cobre y otros materiales, así como, conductos plásticos y otros tipos de materiales largos de forma segura y ergonómica. El portatubos tiene apertura por ambos extremos para facilitar la carga y descarga del material. Los cierres cuentan con un sistema de seguridad integrado, para impedir el robo del material transportado.
- fr Accessoire permettant de transporter des tuyaux en toute sécurité sur le toit d'un véhicule utilitaire léger. Le CRUZ Pipe Carrier a été spécialement conçu pour permettre au professionnel de transporter des tuyaux en cuivre et tuyaux en plastique ou autres matériaux longs en toute sécurité et de manière ergonomique sur son véhicule. Le porte-tube possède une ouverture aux deux extrémités pour faciliter le chargement et le déchargement du matériau. Les embouts verrouillables sont dotés d'un système de sécurité intégré pour empêcher le vol du matériel transporté.
- de Zubehör für den sicheren Transport von Rohren auf dem Dach eines leichten Nutzfahrzeugs. Der CRUZ Pipe Carrier wurde speziell für Profis entwickelt, um Kupferrohre, Kunststoffrohre und andere lange Materialien sicher und ergonomisch auf dem Fahrzeug zu transportieren. Der Rohrträger hat an beiden Enden eine Öffnung zum einfachen Be- und Entladen des Materials. Die Verschlüsse sind mit einem Sicherheitssystem ausgestattet, das den Diebstahl des transportierten Materials verhindert.

... other languages 44



		↔ ¹	📦 ²	⬇️ Max: Ø 15mm ³	⬇️ Max: Ø 20mm ³	🔑
941-035	CRUZ Pipe Carrier extension +1m	1016,5x185x131	3,6	66	40	■
941-036	CRUZ Pipe Carrier 2m	2165x185x146	7,2	66	40	■
941-037	CRUZ Pipe Carrier 3m	3183x185x146	10,5	66	40	■

¹ mm (LxWxH), ² kg, ³ quantity of pipes

^{*} total years (product registration needed)

↓ 📦 - CRUZ Pipe Carrier 2m



3 years warranty
años de garantía
ans de garantie
jahre garantie *

-
- 📦 - CRUZ Cargo Xpro 2022 SF
- CRUZ Kit LCV
- CRUZ Pipe Carrier 2m

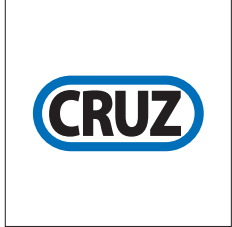

INDEX ←

new

CRUZ Pipe Carrier



pending



pending

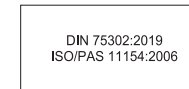

pending



pending



INDEX ←



■ CRUZ Alu Cargo

PT

Barras porta carga de alumínio reforçadas. Perfil com 3 ranhuras. Perfil reforçado de alumínio com três ranhuras para fácil encaixe de acessórios. Excelente aerodinâmica e design, elegante e funcional. Maior resistência e proteção anticorrosiva. Ergonomia: segurança profissional para o carregamento de material sobre o tejadilho.

IT

Barre portacarico in alluminio rinforzate. Profilo con 3 scanalature. Profilo rinforzato in alluminio con tre scanalature per facile ancoraggio di accessori. Ottima aerodinamicità e disegno elegante e funzionale. Migliore resistenza e protezione anticorrosione. Ergonomia: sicurezza professionale per la carica del materiale sopra il tetto.

NL

Aluminium versterkte dakdragers. 3-slots profiel. Versterkt aluminium profiel met drie slouzen voor eenvoudige montage van accessoires. Verbeterde aerodynamische vorm, gestroomlijnd en functioneel ontwerp. Maximale weerstand tegen corrosie. Ergonomia: professionele veiligheid om het materiaal op het dak te laden.

GR

Αλουμινίου θωρακισμένες μπάρες μεταφοράς φορτίου. Προφίλ με 3 στρώματα αλουμινίου. Ενισχυμένο προφίλ αλουμινίου με τρεις υποδοχές για την εύκολη τοποθέτηση των εξαρτημάτων. Ενισχυμένο αεροδυναμικό σχήμα, βελτιωμένος και λειτουργικός σχεδιασμός. Μέγιστη αντοχή στη διάβρωση. Εργονομία: επαγγελματική ασφάλεια για τη φόρτωση στην οροφή.

TR

Güçlendirilmiş alüminyum taşıma barları. 3-Yuvalı Profil. Aksesuarların kolayca monte edilebilmesi için geliştirilmiş 3 yuvalı alüminyum profil. Geliştirilmiş aerodinamik görünüm, sık ve fonksiyonel tasarımı. Maksimum korozyon direnci. Ergonomi: Malzemelerin araç üstüne yüklenmesinde profesyonel güvenlik.

HR

Ojačane šipke za nosače tereta od aluminija. Profil s trostrukim utorima. Ojačan profil od aluminija s trostrukim utorima za jednostavno pričvršćivanje dodatka. Izvršna aerodinamičnost i elegantan i funkcionalni dizajn. Bolja otpornost i antikoroziivna zaštita. Ergonomija: stručna sigurnost za uтовar materijala na krov.

PL

Wzmocnione aluminiowe belki bagażników. Profil z 3 szczelinami. Wzmocniony profil aluminiowy z trzema szczelinami dla łatwego montażu akcesoriów. Ulepszony aerodynamiczny kształt, usprawniona funkcjonalna konstrukcja. Maksymalna odporność na korozję. Ergonomia: Profesjonalne bezpieczeństwo ładowania materiału na dach.

CZ

Hliníkové, vyztužené příčnicki. 3-drážkový profil příčnicku. Vyztužený hliníkový profil se třemi sloty pro jednoduchou instalaci doplňků. Inovovaný aerodynamický tvar, elegantní a funkční design. Maximální odolnost proti korozi. Ergonomie: profesionální zabezpečení pro naložení nákladu na střeche.

HU

Alumínium erősített csomagtartó rudak. 3-vágattal rendelkező profil. Erősített alumínium profil három vágattal a tartozékok könnyebb felszereléséért. Továbbfejlesztett aerodinamikus forma, áramvonalas és funkcionális kialakítás. Maximális korrozóállóság. Ergonomia: professzionális biztonság az anyag felrakásakor a tetőre.

RO

Bare portbagaj din aluminiu ranforsat. Profil cu 3 fante. Profil de aluminiu ranforsat cu trei fante pentru montare usoară a accesoriilor. Formă aerodinamică îmbunătățită și design funcțional. Rezistență maximă la coroziune. Ergonomie: siguranță profesională la încărcarea materialelor pe acoperiș.

SL

Nosilni ojačani drogovi iz aluminija. Profil s 3. zareznimi. Aluminijske ojačane nosilne prečke s 3-režnim profilom za enostavno montažo raznih dodatkov. Izboljšana aerodinamična in funkcionalna oblika. Maksimalna odpornost proti koroziji. Ergonomija: strokovna varnost za tovorjenje materiala na strehi.

BG

Подсилени алуминиеви напречни греди. 3-канален профил. Подсилен алуминиев профил с три канала за лесно закрепване на принадлежностите. Отлична аеродинамика, елегантен и функционален дизайн. По-голяма здравина и антикорозионна защита. Ергономичност: професионално ниво на безопасност при товарене на материалите върху покрива.

■ CRUZ Cargo Xpro

PT

Barras de tejadilho reforçadas com perfil aerodinâmico de aço galvanizado para veículos comerciais ligeiros. As barras de tejadilho CRUZ Cargo Xpro têm um perfil aerodinâmico de secção oval de aço galvanizado, em linha com a estética dos modelos de veículos atuais.

IT

Barre portatutto rinforzate con profilo aerodinamico in acciaio galvanizzato per veicoli commerciali leggeri. Le barre portatutto CRUZ Cargo Xpro hanno un profilo aerodinamico a sezione ovale in acciaio galvanizzato, in linea con l'estetica dei modelli di veicoli attuali.

NL

Versterkte dakdragers met aerodynamisch profiel van verzinkt staal voor lichte bedrijfsvoertuigen. De CRUZ Cargo Xpro dakdragers hebben een aerodynamisch profiel met ovale doorsnede van verzinkt staal, in lijn met de esthetiek van de huidige voertuigmodellen.

GR

Μπάρες οροφής αεροδυναμικού σχεδιασμού από γαλβανισμένο χάλυβα για ελαφριά επαγγελματικά οχήματα. Οι μπάρες οροφής CRUZ Cargo Xpro διαθέτουν αεροδυναμικό σχεδιασμό οβάλ σχήματος, από γαλβανισμένο χάλυβα, σύμφωνα με την αισθητική των σύγχρονων μοντέλων.

TR

Hafif ticari araçlar için galvanize çelik aerodinamik profille güçlendirilmiş taşıyıcı bar. CRUZ Cargo Xpro taşıyıcı barlar, güncel araç modellerinin estetik görünümü ile uyumlu, galvanize çelikten oval kesitli aerodinamik profille sahiptir.

HR

Čvrsti krovni nosači s aerodinamičnim profilima od galvaniziranog čelika za laka gospodarska vozila. Krovni nosači CRUZ Cargo Xpro izrađeni su od aerodinamičnih profila od galvaniziranog čelika ovalnog presjeka u skladu s estetskim modelima suvremenih vozila.

PL

Wzmocnione dachowe belki o aerodynamicznym profilu wykonane ze stali galvanizowanej do lekkich pojazdów komercyjnych. Owalny odcinzek ze stali galvanizowanej dachowych belek CRUZ Cargo Xpro posiadają aerodynamiczny profil podkreślający estetykę współczesnych modeli pojazdów.

CZ

Zesílené střešní nosiče s aerodynamickým profilem z pozinkované oceli pro lehká užitková vozidla. Střešní nosiče CRUZ Cargo Xpro mají aerodynamický profil s oválným průřezem z galvanizované oceli v souladu s estetickou současných modelů vozidel.

HU

Megerősített horganyzott acél tetőcsomagtartók aerodinamikus profilal kishaszonyjárművekhez. A CRUZ Cargo Xpro tetőcsomagtartó horganyzott acélból készül, ovális keresztmetszetű aerodinamikus profilal rendelkezik, a mostani járműmodellek esztétikai megjelenésével összhangban.

RO

Bare transversale ranforsate cu profil aerodinamic din oțel galvanizat pentru vehicule comerciale usoare. Barele transversale CRUZ Cargo Xpro au profil aerodinamic, cu secțiune ovală din oțel galvanizat, în concordanță cu estetica modelelor de vehicule actuale.

SL

Strešni nosilci ojačani z aerodinamičnim profilom iz pocinkanega jekla za lahka gospodarska vozila. Strešni nosilci CRUZ Cargo Xpro imajo aerodinamični profil ovalne oblike iz pocinkanega jekla v skladu z estetsko aktualnih modelov vozil.

BG

Подсилени багажни греди с аеродинамични профили от pocинкована стомана за лекотоварни превозни средства. Гредите CRUZ Cargo Xpro имат аеродинамичен профил с овално сечение, изработен от pocинкована стомана, в съответствие с естетиката на съвременните модели автомобили.

■ CRUZ rear door ladder type B

PT

Escada de acesso para a porta traseira. Escada para aceder ao porta-bagagens do veículo que se coloca sobre a porta traseira da carrinha. Adaptável a todo o tipo de portas sem necessidade de realizar perfurações. Possibilidade de colocação inclusivamente em carrinhas com partes envidraçadas. Maior rigidez graças aos tubos de maior secção. Acabamento em pintura rugosa anti-deslizamento. Cumpre a normativa anti-deslizamento DIN 51130; Anti-slip R-11. Necessário para a sua montagem o CRUZ Kit rear door ladder específico para cada veículo. Não compatível com portão traseiro.

IT

Scala di accesso al portellone posteriore Scala di accesso al portabagagli del veicolo da posizionare sul portellone posteriore del furgone. Adattabile a ogni tipo di portellone senza che sia necessario effettuare perforazioni. Possibilità di posizionarlo anche su furgoni vetrati. Elevata rigidità grazie ai tubi di maggiore spessore. Finitura in vernice ruvida antiscivolo. Osserva la normativa antiscivolo DIN 51130; Anti-slip R-11. Per il montaggio è necessario il CRUZ Kit rear door ladder specifico per ogni veicolo. Non compatibile con veicoli dotati di portellone posteriore.

NL

Toegangsladder voor het achterportier. Ladder om bij de dakdrager te komen en die op het achterportier van de bestelwagen wordt geplaatst. Kan worden aangepast aan elk type portier zonder dat geboord moet worden. Kan ook worden geplaatst in bestelwagens met veel beglazing. Hogere sterkte dankzij de buizen met ruime doorsnede. Afwerking in ruwe lak met anti-slipeigenschappen. Voldoet aan norm DIN 51130; Anti-slip R-11. Specifieke CRUZ Kit rear door ladder voor elk voertuig nodig voor de montage. Niet compatibel met achterklep.

GR

Σκάλα πρόσβασης στην πίσω πόρτα. Σκάλα για την πρόσβαση στη χάρα αποσκευών του οχήματος, η οποία τοποθετείται στην πίσω πόρτα του φορτηγού. Προσαρμόζεται σε κάθε είδους πόρτα χωρίς να χρειάζονται διατρήσεις. Δυνατότητα τοποθέτησης ακόμη και σε φορτηγάκια με τζάμια. Μεγαλύτερη ακαμψία χάρη στους σωληνούς μεγαλύτερης διαμέτρου. Βαφή ανάλυσης υφής με αντιολισθητικές ιδιότητες. Πληροί το πρότυπο αντιολίσθησης DIN 51130 Anti-slip R-11. Απαραίτητο για τη συναρμολόγηση του CRUZ Kit rear door ladder ειδικό για κάθε όχημα. Δεν είναι συμβατό με το πορτμπανακάς.

TR

Arka kapı için giriş merdiveni. Kamyonetin arka kapısı üzerinde bulunan araç raflarına erişmek için merdiven. Delik açmaya gerek olmadan her kapı türüne uyum sağlar. Minibüslere bile kurulum imkanı. Daha büyük kesitli borular sayesinde üstün sağlamlık. Kaymayı önleyici pürüzlü bir boya ile boyanmıştır. DIN 51130; Anti-slip R-11 kaymayı önleme standardına uygundur. Montajı için her araca özgü CRUZ Kit rear door ladder gereklidir. Bagaj kapisiyla uyumlu değildir.

HR

Ljestve za pristup na stražnjim vratima. Ljestve za pristup krovnom nosaču vozila smještene iznad stražnjih vrata kombi vozila. Prilagodljive za sve vrste vrata bez bušenja rupa. Moguće postavljanje i na ostakljena kombi vozila. Veća krutost zahvaljujući cijevima većeg presjeka. Završna obrada s hrpavom površinom za sprječavanje proklizavanja. Zadovoljava normu za sprječavanje proklizavanja DIN 51130; Anti-slip R-11. Potrebno montirati CRUZ Kit rear door ladder na poseban način za svako vozilo. Nije kompatibilno s vozilima sa stražnjim vratima.

PL

Drabinka na tylné drzwi. Drabinka zapewniająca dostęp do bagażnika dachowego pojazdu, montowana na tylnych drzwiach furgonetki. Pasuje do różnego rodzaju drzwi – bez potrzeby wiercenia otworów. Z możliwością mocowania nawet na furgonetkach z przeszklonymi drzwiami. Szywniejsza dzięki rurom o większym przekroju. Z przeziwoślizgowym, chropowatym wykończeniem. Spełnia normy antypoślizgowe DIN 51130; klasa R11. Do montażu niezbędny jest zestaw CRUZ Kit rear door ladder, specjalny dla każdego pojazdu. Niekompatybilna z tylną klapą.

CZ

Přístupový žebřík na zadní dveře. Žebřík pro přístup ke střešnímu nosiči vozu, s umístěním na zadní dveře dodávky. Lze přizpůsobit jakémukoli typu dveří, bez potřeby vrtání. Možnost umístění i na prosklené dodávky. Větší pevnost díky trubkám s větším průměrem. Povrch s hrubým protiskluzovým nátěrem. Splňuje předpis DIN 51130; Anti-slip R-11. Žebřík rear door ladder potřebný pro montáž CRUZ Kit dle specifikací každého vozidla. Nejen kompatibilní se zadními výklopnými dveřmi.

HU

Létra a hátsó ajtóhoz. A furgon hátsó ajtajára szerelt létra, amellyel hozzá lehet férni a tető poggyszartatóhoz. Minden ajtótipusnál alkalmazható, nincs szükség furatokra a karosszérián. Úvegezett hátsó ajtókra is felszerelhető. A nagyobb átmérőjű csövek nagyobb szilárdságot biztosítanak. Csúszásmentes, érdes festett felület. Megfelel a csúszásmentességről szóló DIN 51130 és Anti-slip R-11 szabványnak. Felszereléséhez a minden járműhöz speciálisan tervezett „CRUZ Kit rear door ladder” szerelőkészlet szükséges. Nem kompatibilis felélfé nyíló hátsó ajtóval.

RO

Scară pentru portiera din spate. Scară pentru accesul la cutia portbagaj a vehiculului, atașabilă la portiera din spate a furgonetei. Se adaptează la toate tipurile de portiere, fără a fi nevoie de perforare. Poate fi depozitată chiar și în furgonetele cu geam. Rigiditate mărită asigurată de secțiunea mai mare a tuburilor. Finisaj cu vopsea rugoasă antiderapantă. Conforme cu standardul antiderapaj DIN 51130; Anti-slip R-11. Pentru montare este necesar kitul CRUZ Kit rear door ladder, specific fiecărui vehicul. Nu este compatibil cu vehiculele cu hayon.

SL

Lestev za dostop za zadnja vrata. Lestev za dostop do strešnega nosilca vozila za namesitev na zadnja vrata kombija. Prilagodljiva za vse vrste vrat, brez vrtanja. Možnost namestitve tudi na zastekljene dele kombija. Večja trdnost zahvaljujoč cevem večji dimenziji. Površinsko obdelana z grobim nadržem premazom. V skladu z uredbo o odpornosti proti drsenju DIN 51130; Anti-slip R-11. Za montažo je potreben CRUZ Kit rear door ladder, specifičen za vsako vozilo. Ni združljivo s prtljajnimi vrati.

BG

Стълба за достъп за задната врата. Стълба за достъп до багажника на автомобила, която се поставя на задната врата на буса. Адаптира се към всички видове врати, без да е необходимо пробиване на отвори. Възможност за поставяне и към остъклени врати. По-стабилна благодарение на тръбите с по-голямо сечение. Покритие с грапава боя против подхлъзване. Отговаря на стандарта за устойчивост на хлъзгане DIN 51130; устойчивост на хлъзгане R-11. Необходим за монтажа комплект CRUZ Kit rear door ladder, специфичен за всеки автомобил. Съвместим с отваряща се нагоре задна врата.

■ CRUZ Evo Rack Alu module

PT

Porta-bagagens ergonómico fabricado em alumínio anodizado mate. Porta-bagagens fabricado completamente em alumínio com design compacto, robusto e ergonómico. Inovador sistema de fixação rápida dos tubos de grade, agora em alumínio, com design aerodinâmico e calha posterior para o acoplamento de acessórios. Perfis laterais com ranhura dupla para uma maior flexibilidade e ajuste a cada modelo de veículo.

IT

Portabagagli ergonomico fabbricato in alluminio anodizzato opaco. Portabagagli fabbricato completamente in alluminio, con design compatto, robusto ed ergonomico. Innovativo sistema di fissaggio rapido dei tubi della griglia, ora in alluminio, con design aerodinamico e guida posteriore per l'abbinamento di accessori. Profili laterali con doppia scanalatura per maggiore flessibilità e adattamento a ciascun modello di veicolo.

NL

Ergonomische dakdrager vervaardigd in mat geanodiseerd aluminium. Volledig aluminium dakdrager met compact, robuust en ergonomisch ontwerp. Innovatief systeem voor snelle bevestiging van de roosterbuizen, nu in aluminium, met aerodynamisch ontwerp en geleiding achteraan voor de koppeling van accessoires. Zijprofielen met dubbele gleuf voor meer flexibiliteit en aanpassing aan elk voertuigmodel.

GR

Εργονομική σχάρα αποσκευών κατασκευασμένη από ανωδιωμένο αλουμίνιο σε ματ. Σχάρα αποσκευών κατασκευασμένη ολόκληρη από αλουμίνιο με συμπαγή, ισχυρό και εργονομικό σχεδιασμό. Νεωτεριστικό σύστημα γρήγορης προσαρμογής των σωληνών της σχάρας, τώρα από αλουμίνιο, με αεροδυναμικό σχέδιο και πίσω διάδρομο

για τη σύνδεση των αξεσουάρ. Πλαϊνά προφίλ με διπλή σχισμή για καλύτερη προσαρμοστικότητα και στερέωση σε κάθε μοντέλο οχήματος.

TR

Mat anotlanmış alüminyumdan üretilmiş ergonomik raflar. Kompakt, sağlam ve ergonomik bir tasarıma sahip, tamamen alüminyumdan üretilmiş raflar. Aksesuarların takılması için arka palet ve aerodinamik tasarıma sahip, şimdi alüminyumdan üretilen izgara borularının yenilikçi seri bağlama sistemi. Her araç modeline uygun ve üstün esneklik için çift oluklu yan profiller.

HR

Ergonomski krovni nosač izrađen od mat anodiziranog aluminija. Krovni nosač izrađen u potpunosti od aluminija kompaktnog dizajna, robustan i ergonomski konstruiran. Inovativan sustav za brzo pričvršćivanje cijevi rešetke, sada od aluminija, s aerodinamičnim dizajnom i stražnjom rešetkom za spajanje dodatne opreme. Bočni profili s dvostrukim utorima za veću fleksibilnost i prilagodljivost svakom modelu vozila.

PL

Ergonomiczny bagażnik dachowy wykonany z matowego, anodowanego aluminium. Bagażnik dachowy wykonany w całości z aluminium o kompaktowym, solidnym i ergonomicznym kształcie. Innowacyjny system szybkiego montowania poprzecznych rurek – teraz aluminiowych – o aerodynamicznym kształcie i z tylnym rowkiem T do montażu akcesoriów. Boczne profile z podwójną szczeliną zapewniające większą elastyczność oraz dopasowujące się do każdego modelu pojazdu.

CZ

Ergonomický střešní nosič vyrobený z matného eloxovaného hliníku. Střešní nosič, kompletné vyrobený z hliníku s kompaktním, robustným i ergonomickým designem. Inovatívny systém rýchleho upevnení príčnickú (trubek) střešného nosiče, nyní z hliníku, s aerodynamickým designem a zadní lištou pro upevnění příslušenství. Boční profily s dvojitou drážkou pro lepší flexibilitu a přizpůsobení jednotlivým modelům vozidel.

HU

Matt, eloxált alumíniumból gyártott ergonomikus poggyásztartó. Erős, ergonomikus és kompakt kialakítású alumínium csomagtartó. Új rendszerű, gyorsrögzítésű alumínium keresztcsövek aerodinamikus kialakítással, hátulsó kiegészítő rúddal a tartozékok rögzítéséhez. A dupla horonnyal ellátott oldalsó profilok rugalmasabbak és jobban illeszkednek az egyes járműtípusokhoz.

RO

Cutie portbagaj ergonomică fabricată din aluminiu anodizat mat. Cutie portbagaj fabricată integral din oțel galvanizat cu design compact, robust și ergonomic. Sistem inovator de fixare rapidă a tuburilor tip grilă, acum din aluminiu, cu design aerodinamic și șant posterior pentru prinderea accesoriilor. Profiluri laterale cu nervură dublă care asigură o mai mare flexibilitate și ajustare la fiecare model de vehicul.

SL

Ergonomsko oblikovan strešni nosilec, izdelan iz matirnega eloksiranega aluminija. Strešni nosilec, v celoti izdelan iz aluminija, ter kompaktno, robustno in ergonomsko oblike. Inovativen sistem hitrega pritrdjevanja cevi rešetke, sedaj iz aluminija, aerodinamične oblike ter zadnje palice za večjo fleksibilnost in prilagodljivost vsakemu modelu vozila.

BG

Εργονομичен багажник, изработен от матов анодизиран алуминий. Багажник, изработен изцяло от алуминий, с компактен дизайн, здрав и ергономичен. Иновативна система за бързо закрепване на тръбите на скарата, вече

от алуминий, с аеродинамичен дизайн и задна релса за закрепване на принадлежности. Странични профили с два канала за по-голяма гъвкавост и напасване към всеки модел автомобил.

■ CRUZ Evo Rack Pro

PT

Porta-bagagens de aço galvanizado extremamente robusto e ergonómico. Maior resistência a condições climáticas extremas graças ao fabrico em aço galvanizado. Maior aerodinâmica graças ao novo defletor. Protecções laterais de maior altura o que garante uma maior segurança da carga transportada.

IT

Portabagagli in acciaio galvanizzato con design compatto, robusto ed ergonomico. Grande rigidità strutturale grazie a una progettazione specifica per ogni modello di veicolo e a profili di maggiore spessore. Maggiore resistenza a condizioni climatiche estreme, grazie alla fabbricazione in acciaio galvanizzato. Migliore aerodinamica grazie al nuovo deflettore. Sponde laterali più alte per una maggiore sicurezza del carico trasportato.

NL

IJster robuuste en ergonomische dakdrager van verzinkt staal. Grote structurele sterkte dankzij het specifieke ontwerp voor elk voertuigmodel en de profielen met grotere doorsnede. Hogere weerstand tegen extreme weersomstandigheden dankzij de vervaardiging in verzinkt staal. Betere aerodynamiek dankzij de nieuwe windgeleider. Hogere zijleuningen, waardoor de vervoerde lading beter beveiligd wordt.

GR

Σχάρα αποσκευών από γαλβανισμένο χάλυβα, άκρως ισχυρή και εργονομική. Μεγάλη δομική ακαμψία λόγω του ότι έχουν σχεδιαστεί ειδικά για κάθε μοντέλο οχήματος και διαθέτουν προφίλ μεγαλύτερων διαμέτρων. Μεγαλύτερη αντίσταση σε αντίξοες καιρικές συνθήκες χάρη στην κατασκευή της από γαλβανισμένο χάλυβα. Καλύτερη αεροδυναμική χάρη στο νέο αλουμινένιο εκτροπέα. Κάθετα κύκλωματα μεγαλύτερου ύψους, που εξασφαλίζουν περισσότερη ασφάλεια του μεταφερόμενου φορτίου.

TR

Son derece sağlam ve ergonomik galvanize çelik raflar. Her araç modeli için özel olarak tasarlanmış olması ve daha büyük kesitli profillere sahip olması sayesinde, yüksek yapışal dayanıklılık. Üretiminde kullanılan galvanize çelik sayesinde sert iklim koşullarına daha yüksek direnç. Tasarımı, profesyonel kullanicılara aracin çatisina malzeme yükleyerek taşımak için güvenli bir sistem sunar. Yeni deflektör sayesinde daha üstün aerodinamizm. Taşınan yükün daha emniyetli olmasını sağlar, daha yüksek yan korkuluklar.

HR

Iznimno robustan i ergonomski dizajniran krovni nosač od galvaniziranog čelika. Velika struktura čvrstoća, jer su dizajnirani posebno za svaki model vozila i imaju profile većeg presjeka. Povećana otpornost u ekstremnim vremenskim uvjetima zahvaljujući izradi od galvaniziranog čelika. Bolja aerodinamičnost zahvaljujući novom deflektoru. Više bočne prečke omogućavaju povećanu sigurnost tereta koji se prevozi.

PL

Wyjątkowo solidny i ergonomiczny bagażnik dachowy ze stali galvanizowanej. Bardzo mocna struktura – została specjalnie zaprojektowana dla każdego modelu pojazdu i przystosowana do większych rozmiarów. Większa odporność na ekstremalne warunki klimatyczne dzięki wykonaniu ze stali galvanizowanej. Lepsza aerodynamika

dzięki nowemu spojlerowi. Wyższe boczne poręcze zapewniające większe bezpieczeństwo przewożonego ładunku.

CZ

Střešní nosiče z galvanizovaného oceli, extrémně robustní a ergonomické. Vysoká strukturní pevnost díky speciálnímu designu pro každý jednotlivý model vozů a profily s větším průměrem. Vzhledem k tomu, že jsou vyrobeny z galvanické oceli, mají zvýšenou odolnost vůči extrémním klimatickým podmínkám. Lepší aerodynamika díky novému deflektoru. Vyšší boční lišty, zaručující vyšší bezpečnost přepravovaného nákladu.

HU

Rendkívül erős és ergonomikus kialakítású, galvanizott acél poggyásztartó. Nagy szerkezeti szilárdságot biztosít, mivel kifejezetten az egyes járműtípusokhoz és nagyobb keresztmetszetű elemekhez tervezték. A galvanizált acél kialakításnak köszönhetően jobban ellenáll a szélsőséges időjárásnak. Az új terelőlemez jobb aerodinamikai jellemzőket biztosít. A magasabb oldalsó korlátoknak köszönhetően biztonságosabb a rakomány szállítása.

RO

Cutie portbagaj din oțel galvanizat extrem de robust și ergonomic. Structură foarte rigidă, proiectată special pentru fiecare model de vehicul, cu profiluri cu secțiune mai mare. Rezistență mărită la condiții meteorologice extreme multumită oțelului galvanizat din care sunt fabricate. Aerodinamică sporită multumită noului deflector din. Balustrade laterale mai înalte, care garantează o siguranță mai ridicată a încărcăturii transportate.

SL

Izjemno robusten in ergonomsko oblikovan pocinkan jeklen strešni nosilec. Trdnost strukture je velika, saj so nosilci oblikovani za vsak model vozila posebej in imajo večje profile. Ker so izdelani iz pocinkanega jekla, zagotavljajo večjo odpornost v ekstremnih klimatskih razmerah. Večja aerodinamika zaradi novega zaradi novega odbojnika. Višji stranski letvi, kar za zagotavlja večjo varnost pri prevozu tovora.

BG

Багажник от галванизирана стомана, изключително здрав и ергономичен. Голяма конструктивна здравина благодарение на факта, че са специално проектирани за всеки модел автомобил, а профилите им са с по-голямо сечение. По-добра устойчивост на екстремни климатични условия, тъй като са произведени от галванизирана стомана. Оптимизирана аеродинамика благодарение на новия дефлектор. Странични прегради с по-голяма височина, осигуряващи по-голяма безопасност на превозваните товари.

■ CRUZ Evo Rack module

PT

Porta-bagagens de aço galvanizado com design compacto, robusto e ergonómico. Maior resistência a duras condições climáticas graças ao fabrico em aço galvanizado. Estrutura robusta com um novo design que confere uma maior rigidez ao conjunto. Inovador sistema de fixação rápida dos tubos de grade que, unidos ao novo design de tubos laterais com calha interior continua, melhoram o tempo de montagem. Redesign completo de medidas para melhorar a adaptação a cada modelo de veículo.

IT

Portabagagli in acciaio galvanizzato con design compatto, robusto ed ergonomico. Maggiore resistenza a condizioni climatiche dure, grazie alla fabbricazione in acciaio galvanizzato. Struttura robusta con nuovo design che conferisce maggiore rigidità d'insieme. Innovativo sistema di fissaggio rapido dei tubi griglia che, insieme al nuovo design

dei tubi laterali con guida interna continua, riduce il tempo di montaggio. Nuovo design completo delle misure per un adattamento migliore a ogni modello di veicolo.

NL
Dakdrager van verzinkt staal met compact, robuust en ergonomisch ontwerp. Hogere weerstand tegen ongunstige weersomstandigheden dankzij de vervaardiging in verzinkt staal. Robuuste structuur met nieuw ontwerp dat het geheel een hogere rigiditeit geeft. Innovatief systeem voor snelle bevestiging van de roosterbuizen, die samen met het nieuwe ontwerp van de zijbuizen met doorlopende binnengeleiding de montagetijd verkorten. Compleet nieuw ontwerp van de afmetingen voor betere aanpassing aan elk voertuigmodel.

GR
Σχάρα αποσκευών από γαλβανισμένο χάλυβα με συμπαγή, ισχυρό και εργονομικό σχεδιασμό. Μεγαλύτερη αντίσταση σε αντίξοες καιρικές συνθήκες χάρη στην κατασκευή της από γαλβανισμένο χάλυβα. Ισχυρή δομή με νέο σχεδιασμό που προσδίδει μεγαλύτερη ακαμψία στο σύνολο εξοπλισμού. Νεωτεριστικό σύστημα γρήγορης προσαρμογής των σωλήνων της σχάρας, οι οποίοι, ενωμένοι με τους εγκάρσιους σωλήνες νέου σχεδιασμού με συνεχόμενο εσωτερικό διάδρομο, βελτιώνουν τον χρόνο συναρμολόγησης. Πλήρης ανασχεδιασμός διαστάσεων για καλύτερη προσαρμογή σε κάθε μοντέλο οχήματος.

TR
Kompakt, sağlam ve ergonomik bir tasarımı sahip, galvanize çelikten raflar. Üretiminde kullanılan galvanize çelik sayesinde sert iklim koşullarına daha yüksek direnç. Araca daha üstün dayanıklılık sağlayan yeni tasarımı sağlam yapı. Yeni yan boru tasarımı sürekli iç palet ile birleştirilen izgara borularının yenilikçi serî baglama sistemi, montaj süresini kısaltır. Her araç modeline daha iyi uyum sağlamak üzere eksiksiz şekilde yeniden tasarlanmış ölçüler.

HR
Krovni nosač od galvaniziranog čelika kompaktnog dizajna, robustan i ergonomski konstruiran. Povećana otpornost u teškim vremenskim uvjetima zahvaljujući izradi od galvaniziranog čelika. Robusna konstrukcija s novim dizajnom kojime se postiže veća krutost kompleta. Inovativni sustav brzog pričvršćivanja cijevi rešetke koji zajedno s novim dizajnom bočnih cijevi s uzdužnom kliznom tračnicom, skraćuju vrijeme potrebno za montažu. Potpuno novi dizajn mjera za bolju prilagodbu prema svakom modelu vozila.

PL
Bagażnik dachowy ze stali galvanizowanej o kompaktowym, solidnym i ergonomicznym kształcie. Większa odporność na trudne warunki klimatyczne dzięki wykonaniu ze stali galvanizowanej. Mocna struktura o nowym designie, nadająca większą sztywność zestawowi. Innowacyjny system szybkiego montowania poprzecznych rurek, które wraz rurkami bocznymi o nowym designie i z wewnętrznym rowkiem skracają czas montażu. Całkowicie zmienione wymiary, dzięki czemu lepiej dopasowuje się do każdego modelu pojazdu.

CZ
Střešní nosič z galvanizované oceli s kompaktním designem, robustní a ergonomický. Vyšší odolnost v těžkých klimatických podmínkách, díky výrobě z galvanické oceli. Robustní struktura s novým designem, která dodává sestavě vyšší pevnost. Inovativní systém pro rychlé upevnění příčnic (trubek) střešního nosiče, které společně s novým designem podélníků (bočních trubek) s kontinuální vnitřní kolejničící urychlují čas montáže. Kompletní přepracování rozměrů pro lepší přizpůsobení jednotlivým modelům vozů.

HU
Erős, ergonomikus és kompakt kialakítású, horganyzott acél csomagtartó. A galvanizált acél alkalmazásának köszönhetően jobban ellenáll a szélsőséges időjárásnak.

Az új formatervezésű, erős kialakítás növeli a szerkezet szilárdságát. Új rendszerű, gyorsrögzítésű keresztcsövek, amelyek az új kialakításnak, folytonos belső sínnel ellátott oldalcsövekhez kapcsolódnak, ezáltal gyorsabban felszerelhető.

RO
Cutie portbagaj din oțel galvanizat cu design compact, robust și ergonomic. Rezistentă mărîtă la condiții meteorologice aspre multumită oțelului galvanizat din care este fabricată. Structură robustă, cu un nou design, prin care ansamblul devine mult mai rigid. Sistem inovator de fixare rapidă a tuburilor tip grilă care, în combinație cu noul design al tuburilor laterale cu șanț interior continuu, reduc timpul de montaj. Redimensionare integrală pentru o mai bună adaptare la fiecare model de vehicul.

SL
Pocinkani jekleni strešni nosilec kompaktno, robustno in ergonomsko oblike. Izdelan iz pocinkanega jekla, kar zagotavlja večjo odpornost v težkih klimatskih razmerah. Robustna struktura nove oblike, ki celoti zagotavlja večjo trdnost. Inovativen sistem hitrega pritjevanja cevi rešetke, ki povezane z novo obliko stranskih cevi z notranjimi palicami skrajšajo čas montaže. Popolno preoblikovanje mer za boljše prileganje vsakemu modelu vozila.

BG
Багажник от галванизирана стомана с компактен дизайн, здрав и ергономичен. По-добра устойчивост на тежки климатични условия, тъй като са произведени от галванизирана стомана. Здрава конструкция с нов дизайн, който придава по-голяма стабилност на комплекта. Иновативна система за бързо закрепване на тръбите на скапата, които заедно с новия дизайн на страничните тръби с непрекъсната вътрешна релса, намаляват времето за сглобяване. Пълно актуализиране на размерите за по-добро приспособяване към всеки модел автомобил.

■ CRUZ Safari

PT
Módulo porta-bagagens especialmente concebido para veículos 4x4. O módulo CRUZ Safari é um porta-bagagens robusto, duradouro e com grande capacidade de carga. O seu desenho inclui balastradas por todo o seu perímetro e um defletor integrado de origem para uma melhor aerodinâmica e segurança. Grande variedade de acessórios específicos, compatíveis com os restantes porta-bagagens CRUZ de aço e criados para satisfazer as necessidades do utilizador de veículos 4x4.

IT
Modulo portabagagli appositamente progettato per veicoli 4x4. Il modulo CRUZ Safari è un portabagagli robusto e durevole, con un'elevata capacità di carico. Il modello è dotato di corrimano lungo tutto il perimetro e deflettore integrato di serie, per migliori prestazioni aerodinamiche e maggiore sicurezza. Grande varietà di accessori specifici, compatibili con gli altri portabagagli CRUZ in acciaio, progettati per soddisfare le necessità degli utenti di veicoli 4x4.

NL
Bagagedragermodule speciaal ontworpen voor 4x4 voertuigen. De CRUZ Safari-module is een robuuste, duurzame bagagedrager met groot laadvermogen. Het ontwerp bevat rondom-rail en een geïntegreerde afschermplaat, voor betere aerodynamica en veiligheid. Ruim aanbod van specifieke accessoires, compatibel met de rest van de stalen CRUZ-dakdragers en ontworpen om aan alle behoeften van de gebruiker van 4x4 voertuigen te voldoen.

GR
Μονάδα αποσκευών ειδικά σχεδιασμένη για οχήματα 4x4. Η μονάδα CRUZ Safari είναι ένα σύστημα αποσκευών ανθεκτικό, δυνατό και με μεγάλη χωρητικότητα φορτίου. Ο σχεδιασμός του περιλαμβάνει κυκλιδόμενα σε όλη του την περίμετρο και ένα ενσωματωμένο χώρισμα για καλύτερη αεροδυναμική και ασφάλεια. Μεγάλη ποικιλία ειδικών ανταλλακτικών, συμβατών με τις υπόλοιπες χαλύβδινες σχάρες CRUZ και σχεδιασμένα για να ανταποκρίνονται στις ανάγκες του χρήστη με οχήματα 4x4.

TR
Özellikle 4x4 araçlar için tasarlanmış port bagaj modülü. CRUZ Safari, dayanıklı, sağlam ve yüksek yük kapasiteli bir port bagaj modülüdür. Tasarımı, çevresinde korkuluk ile daha iyi aerodinamik ve güvenlik sağlanması için bir dizi entegre deflektör barındırır. 4x4 araç kullanımını ihtiyacılarını karşılamak üzere tasarlanan, çelik CRUZ raflarının geri kalanı ile uyumlu, geniş bir spesifik aksesuar ürün yelpazesi.

HR
Modul krovnog nosača posebno osmišljen za vozila 4x4. Modul CRUZ Safari čvrst je i trajni krovni nosač izvršne nosivosti. Model uključuje bočne prečke u čitavom opsegu i ugrađene serijski deflektor za bolju aerodinamičnost i sigurnost. Veliki izbor specifične dodatne opreme, kompatibilne s ostalim čeličnim krovnim nosačima CRUZ, a koja je osmišljena kako bi zadovoljila potrebe korisnika vozila 4x4.

PL
Moduł bagażnika dachowego zaprojektowany specjalnie dla pojazdów 4x4. Moduł CRUZ Safari to bagażnik solidny, wytrzymały i o dużej pojemności. Jego konstrukcja obejmuje relingi na całym obwodzie i seryjnie wbudowany deflektor dla lepszej aerodynamiki i bezpieczeństwa. Duża różnorodność specjalnie zaprojektowanych akcesoriów, kompatybilnych z pozostałymi stalowymi bagażnikami dachowymi CRUZ i przystosowanych do potrzeb użytkowników pojazdów 4x4.

CZ
Model nosiče speciálně vytvořený pro vozidla 4x4. Model CRUZ Safari je robustní a odolný nosič s vysokou nosností. Tento model zahrnuje zábradlí po celém obvodu a sériový integrovaný deflektor pro lepší aerodynamiku a bezpečnost. Široký výběr specifického příslušenství kompatibilního s dalšími střešními nosiči z oceli, které bylo navrženo tak, aby vyhovovalo potřebám uživatelů vozidla 4x4.

HU
Kifejezetteen négykerék-meghajtású járművekhez tervezett csomagtartómodul. Masszív, hosszú élettartamú, nagy teherbírású CRUZ Safari csomagtartómodul. A teljes kerületén körbefutó rács és a szérialfelszereltséghez tartozó integrált légtérelő növeli a biztonságát és javítja a menetteljesítményt. Speciális tartozékok széles skálája, amelyek kompatibilisek a többi C acél poggyásztartóval, és kielégítik a négykerék-meghajtású járművet használók igényeit is.

RO
Modul portbagaj special conceput pentru vehicule 4x4. Modulul CRUZ Safari este un portbagaj robust, durabil și de mare capacitate de încărcare. Designul său include șine pe întregul perimetru și un deflector de serie încorporat, pentru aerodinamică și siguranță sporite. O gamă largă de accesorii specifice, compatibile cu celelalte cutii portbagaj CRUZ din oțel, proiectate pentru a satisface nevoile utilizatorilor de vehicule 4x4.

SL
Modul prtlačnjnika, ki je posebej oblikovan za terenska vozila. Modul CRUZ Safari je robusten, trpežen prtlačnjnik z veliko nosilnostjo. Za boljše dinamiko in varnost ta model vključuje standardne oprijemne drogeve po vsem svojem obodu in

vgrajen odbojnik. Širok izbor posebnih dodatkov, združljivih z ostalimi strešnimi nosilci CRUZ iz jekla, in oblikovanih za zadovoljitev potreb uporabnika vozil 4x4.

BG
Багажник товарна скара, специално проектиран за високотехнически автомобили 4x4. Модулът CRUZ Safari представлява здрава и издръжлива товарна скара с голяма товарносимост. Дизайнът му включва преграда по цялата обиколка и вграден сериен дефлектор за оптимизиране на аеродинамиката и безопасността. Голямо разнообразие от специфични принадлежности, съвместими с останалите стоманени багажници CRUZ, проектирани в отговор на нуждите на потребителите на високотехнически автомобили 4x4.

■ CRUZ rear door ladder type EF

PT
Escada fixa de acesso para a porta traseira. Escada fixa para aceder ao porta-bagagens do veículo que se coloca sobre a porta traseira da carrinha. Acabamento em pintura rugosa anti-deslizamento. Cumpre a normativa anti-deslizamento DIN 51130; Anti-slip R-11. Compatível unicamente com veiculos sem porta traseira envidraçada. Não compatível com portão traseiro.

IT
Scala fissa di accesso al portellone posteriore. Scala fissa di accesso al portabagagli del veicolo da posizionare sul portellone posteriore del furgone. Finitura in vernice ruvida antiscivolo. Osserva la normativa antiscivolo DIN 51130; Anti-slip R-11. Compatibile unicamente con veicoli privi di portellone posteriore vetrato. Non compatibile con veicoli dotati di portellone posteriore.

NL
Vaste toegangsladder voor het achterportier. Vaste ladder om bij de dakdrager te komen en die op het achterportier van de bestelwagen wordt geplaatst. Afwerking in ruwe lak met anti-slip-eigenschappen. Voldoet aan norm DIN 51130; Anti-slip R-11. Enkel compatibel met voertuigen zonder glazen achterportier. Niet compatibel met achterklep.

GR
Σταθερή σκάλα πρόσβασης για τη πίσω πόρτα. Σταθερή σκάλα για την πρόσβαση στη σχάρα αποσκευών του οχήματος, η οποία τοποθετείται στην πίσω πόρτα του βαν. Βαφή ανόλυσης υφής με αντιολισθητικές ιδιότητες. Πληροί το πρότυπο αντι-ολισθησης DIN 51130. Anti-slip R-11. Συμβατή μόνο με οχήματα χωρίς την πίσω πόρτα. Δεν είναι συμβατό με το πορτμπγακάς.

TR
Arka kapı için sabit giriş merdiveni. Kamyonetin arka kapısı üzerinde bulunan araç raflarına erişmek için sabit merdiven. Kaymayı önleyici pürüzlü bir boyalı ile boyanmıştır. DIN 51130; Anti-slip R-11 kaymayı önleme standardına uygundur. Sadece camlı arka kapısı olmayan araçlarla uyumludur. Bagaj kapısıyla uyumlu değildir.

HR
Fiksne ljestve za pristup na stražnjim vratima. Fiksne ljestve za pristup krovnom nosaču vozila smještene iznad stražnjih vrata kombi vozila. Završna obrada s hrapavom površinom za sprječavanje proklizavanja. Zadovoljava normu za sprječavanje proklizavanja DIN 51130; Anti-slip R-11. Kompatibilno samo s vozilima bez ostakljenih stražnjih vrata. Nije kompatibilno s vozilima sa stražnjim vratima.

PL
Stała drabinka na tylne drzwi. Stała drabinka zapewniająca dostęp do bagażnika dachowego pojazdu, montowana na tylnych drzwiach furgonetki. Z przeciwpoślizgowym,

chropowatym wykończeniem. Spełnia normy antypoślizgowe DIN 51130; klasa R11. Kompatybilna wyłącznie z pojazdami bez tylnych drzwi z szybą. Niekompatybilna z tylną klapą.

CZ

Pevný žebřík pro přístup k zadním dveřím. Pevný žebřík pro přístup ke střednímu nosiči vozu s umístěním na zadní dveře dodávky. Povrch s hrubým protiskluzovým nátěrem. Splňuje předpis DIN 51130; Anti-slip R-11. Kompatibilní pouze s vozidly bez zasklených zadních dveří. Není kompatibilní se zadními výklopnými dveřmi.

HU

Fix létra a hátsó ajtóhoz. A furgon hátsó ajtajára fixen szerelt létra, amellyel hozzá lehet férni a tetőpoggyásztartóhoz. Csúszásmentes, érdes festett felület. Megfelel a csúszásmentességéről szóló DIN 51130 és Anti-slip R-11 szabványoknak. Csak nem üvegezett hátsó ajtóval rendelkező járművekkel kompatibilis. Nem kompatibilis felfelé nyíló hátsó ajtóval.

RO

Scară fixă de acces pentru portiera din spate. Scară fixă pentru accesul la cutia portbagaj a vehiculului, atașabilă la portiera din spate a furgonetei. Finisaj cu vopsea rugoasă antiderapantă. Conforme cu standardul antiderapaj DIN 51130; Anti-slip R-11. Comptabil doar cu vehiculele fără portieră spate cu geam. Nu este compatibil cu vehiculele cu hayon.

SL

Pritrjena lestev za dostop za zadnja vrata. Pritrjena lestev za dostop do strešnega nosilca vozila za namestitvev na zadnja vrata kombija. Površinsko obdelana z grobim nredsečim premazom. V skladu z uredbo o odpornosti proti drsenju DIN 51130; Anti-slip R-11. Združljivo le z vozili brez zastekljenih zadnjih vrat. Ni združljivo s prtljajnimi vrati.

BG

Фиксирана стълба за достъп за задната врата. Фиксирана стълба за достъп до багажника на автомобила, която се поставя на задната врата на буса. Покритие с грапава боя против подхлъзване. Отговаря на стандарта за устойчивост на хлъзгане DIN 51130; устойчивост на хлъзгане R-11. Съвместим единствено с автомобили без остъклена задна врата. Несъвместим с отваряща се нагоре задна врата.

■ CRUZ Ladder Clamp

PT

Inovador sistema de fixação para escadas com desenho elegante, ergonómico e de montagem rápida. O desenho das fixações para escadas CRUZ Ladder Clamp foi especialmente concebido para garantir que a experiência do utilizador profissional ao carregar e transportar escadas seja fácil, rápida, segura e ergonómica. Desta forma, os utilizadores profissionais podem destinar o seu tempo ao que realmente importa.

IT

Innovativo sistema di fissaggio per scale dal design elegante, ergonomico e a montaggio rapido. Il design dei dispositivi di fissaggio per scale CRUZ Ladder Clamp è stato studiato appositamente per assicurare agli utenti professionali un'esperienza di carico e trasporto delle scale facile, sicura ed ergonomica. Consente loro di risparmiare tempo da destinare alle attività più importanti.

NL

Innovatief ladderklemstelsysteem met een elegante, ergonomische vormgeving dat snel gemonteerd kan worden. Het ontwerp van de CRUZ Ladder Clamp is speciaal bedacht om de professionele gebruiker het laden en dragen

van ladders gemakkelijk, snel, veilig en ergonomisch te maken. Zo kunnen professionele gebruikers hun tijd besteden aan wat echt belangrijk is.

GR

Καινοτόμο σύστημα στήριξης για σκάλες με κομψό, εργονομικό σχεδιασμό και γρήγορη συναρμολόγηση. Ο σχεδιασμός του συστήματος στήριξης για σκάλες CRUZ Ladder Clamp έχει γίνει ειδικά για να κάνει την εμπειρία του επαγγελματία χρήστη εύκολη, γρήγορη, εργονομική και ασφαλή κατά την φόρτωση και μεταφορά σκαλών. Μ' αυτό τον τρόπο, οι επαγγελματίες χρήστες μπορούν να αφιερώσουν τον χρόνο τους σε ό,τι είναι πραγματικά σημαντικό.

TR

Merdivenler için şık, ergonomik ve kolay monte edilebilen bir tasarıma sahip yenilikçi sabitleme sistemi. Merdivenlerde kullanım amaçlı CRUZ Ladder Clamp sabitleme elemanları, profesyonel kullanicılara merdiven taşırcın ve yüklerken kolay, hızlı, güvenli ve ergonomik bir deneyim sunacak şekilde tasarlanmıştır. Bu sayede profesyonel kullanicılar zamanını gerçekten önemli olan diğer konulara ayırabilir.

HR

Inovativni brzomontažni sustav za pričvršćivanje ljestvi elegantnog i ergonomskog dizajna. Dizajn pričvršćivača za ljestve CRUZ Ladder Clamp posebno je osmišljen kako bi se osiguralo da profesionalni korisnik utovari i transportira ljestve na jednostavan, brz, siguran i ergonomski način. Na taj se način profesionalni korisnici mogu posvetiti onome što je zbija važno.

PL

Stala drabinka na tylne drzwi. Stala drabinka zapewniająca dostęp do bagażnika dachowego pojazdu, montowana na tylnych drzwiach furgonetki. Z przeciwpoślizgowym, chropowatym wykończeniem. Spełnia normy antypoślizgowe DIN 51130; klasa R11. Kompatybilna wyłącznie z pojazdami bez tylnych drzwi z szybą. Niekompatybilna z tylną klapą.

CZ

Pevný žebřík pro přístup k zadním dveřím. Pevný žebřík pro přístup ke střednímu nosiči vozu s umístěním na zadní dveře dodávky. Povrch s hrubým protiskluzovým nátěrem. Splňuje předpis DIN 51130; Anti-slip R-11. Kompatibilní pouze s vozidly bez zasklených zadních dveří. Není kompatibilní se zadními výklopnými dveřmi.

HU

Fix létra a hátsó ajtóhoz. A furgon hátsó ajtajára fixen szerelt létra, amellyel hozzá lehet férni a tetőpoggyásztartóhoz. Csúszásmentes, érdes festett felület. Megfelel a csúszásmentességéről szóló DIN 51130 és Anti-slip R-11 szabványoknak. Csak nem üvegezett hátsó ajtóval rendelkező járművekkel kompatibilis. Nem kompatibilis felfelé nyíló hátsó ajtóval.

RO

Scară fixă de acces pentru portiera din spate. Scară fixă pentru accesul la cutia portbagaj a vehiculului, atașabilă la portiera din spate a furgonetei. Finisaj cu vopsea rugoasă antiderapantă. Conforme cu standardul antiderapaj DIN 51130; Anti-slip R-11. Comptabil doar cu vehiculele fără portieră spate cu geam. Nu este compatibil cu vehiculele cu hayon.

SL

Pritrjena lestev za dostop za zadnja vrata. Pritrjena lestev za dostop do strešnega nosilca vozila za namestitvev na zadnja vrata kombija. Površinsko obdelana z grobim nredsečim premazom. V skladu z uredbo o odpornosti proti drsenju DIN 51130; Anti-slip R-11. Združljivo le z vozili brez zastekljenih zadnjih vrat. Ni združljivo s prtljajnimi vrati.

BG

Фиксирана стълба за достъп за задната врата. Фиксирана стълба за достъп до багажника на автомобила, която се поставя на задната врата на буса. Покритие с грапава боя против подхлъзване. Отговаря на стандарта за устойчивост на хлъзгане DIN 51130; устойчивост на хлъзгане R-11. Съвместим единствено с автомобили без остъклена задна врата. Несъвместим с отваряща се нагоре задна врата.

■ CRUZ Pipe Carrier

PT

Acessório para o transporte de tubos de forma segura no tejadilho do veículo comercial ligeiro. O CRUZ Pipe Carrier foi especialmente concebido para os profissionais poderem transportar de forma segura e ergonómica no veículo tubos de cobre e outros materiais, bem como tubos de plástico e outros tipos de materiais longos. O porta-tubos possui uma abertura em ambas as extremidades para facilitar a carga e a descarga do material. As tampas possuem sistema de segurança integrado para evitar o furto do material transportado.

IT

Accessorio per il trasporto sicuro dei tubi sul tetto di veicoli commerciali leggeri. CRUZ Pipe Carrier è stato studiato appositamente per permettere ai professionisti di trasportare tubi di rame e altri materiali, nonché tubi di plastica e altri materiali lunghi in modo sicuro ed ergonomico sul veicolo. Il porta-tubi si apre su entrambe le estremità per facilitare il carico e lo scarico del materiale. Le chiusure sono dotate di un sistema di sicurezza integrato per evitare il furto del materiale trasportato.

NL

Hulpstuk voor het veilig vervoeren van buizen op het dak van lichte bedrijfsvoertuigen. De CRUZ Pipe Carrier is speciaal ontworpen voor de professional, voor veilig en ergonomisch vervoer van koperen pijpen, kunststof buizen en andere lange materialen. De buizendrager kan aan beide kanten geopend worden voor gemakkelijk laden en lossen van het materiaal. De sluitingen hebben een geïntegreerd veiligheidsstelsel om diefstal van het vervoerde materiaal te voorkomen.

GR

Εξόρτημα για την ασφαλή μεταφορά σωλήνων στην οροφή ελαφριού επαγγελματικού οχήματος. Το CRUZ Pipe Carrier σχεδιάστηκε ειδικά, για την επαγγελματική μεταφορά χαλκοσωλήνων κι άλλων υλικών πάνω σε όχημα, καθώς και πλαστικών σωληνώσεων κι άλλου τύπου μακροστενών υλικών με ασφαλή και εργονομικό τρόπο. Το στήριγμα σωλήνων ανοίγει και από τις δύο πλευρές για να διευκολύνει τη φόρτωση και εκφόρτωση του υλικού. Οι κλειδαριές διαθέτουν ενσωματωμένο σύστημα ασφαλείας για την αποφυγή κλοπής του μεταφερόμενου υλικού.

TR

Hafif ticari araç tavanında boruları güvenli taşımak için aksesuar. CRUZ Pipe Carrier, profesyonellerin araçlarının üzerinde bakır veya farklı malzemeden boruları, plastik boruları ve diğer uzun malzemeleri güvenli ve ergonomik şekilde taşımaları için özel olarak tasarlanmıştır. Boru taşıyıcı, iki ucunda malzemelerin yüklenmesini ve indirilmesini kolaylaştıran oluklara sahiptir. Taşınan malzemenin çalınmasını engelleyen entegre güvenlik sistemi kilitlere sahiptir.

HR

Dodatak za siguran transport cijevi na krovu lakog gospodarskog vozila. Nosač za cijevi CRUZ Pipe Carrier posebno je osmišljen kako bi profesionalni korisnik na svojem vozilu na siguran i ergonomski način transportirao bakrene cijevi i druge materijale, poput plastičnih cijevi i drugih vrsta dugih materijala. Nosač za cijevi ima otvor na

oba kraja radi olakšavanja utovara i istovara materijala. Zatvarači imaju integrirani sigurnosni sustav za sprječavanje krađe transportiranog materijala.

PL

Aksesorium do bezpiecznego transportu rurek na dachu lekkiego samochodu dostawczego. CRUZ Pipe Carrier został specjalnie zaprojektowany dla profesjonalistów, aby bezpiecznie i ergonomicznie przewozić na pojeździe rurki miedziane i inne materiały, np. rury z tworzyw sztucznych i inne długie elementy. Uchwyt na rury ma otwory na obu końcach, co ułatwia załadunek i rozładunek materiału. Zamknięcia są wyposażone w zintegrowany system zabezpieczający transportowany ładunek przed kradzieżą.

CZ

Příslušenství pro bezpečnou přepravu trubek na střeše lehkého užitkového vozidla. Nosič trubek CRUZ Pipe Carrier byl speciálně navržen pro profesionály k bezpečné a ergonomické přepravě měděných trubek a dalších materiálů, plastových trubek a jiných dlouhých materiálů na vozidle. Nosič trubek má na obou koncích otvory, který usnadňuje nakládání a vykládání materiálů. Západky mají integrovaný bezpečnostní systém, který zabraňuje krádeži přepravovaného materiálu.

HU

Tartozék a csővek biztonságos szállításához a kishaszonjárművek tetején. A CRUZ Pipe Carrier kifejezetten szakemberek számára készült, hogy biztonságosan és ergonomikusan szállíthassák a hosszú, rézből és más fémekből, illetve különféle műanyagokból készült csöveket a járműveiken. A csőtartó mindkét végén nyílással rendelkezik, amely megkönnyíti az anyag fel- és lerakodását. A zárák integrált biztonsági rendszerrel rendelkezik, amely megakadályozza a szállított anyag ellopását.

RO

Accesoriu pentru transportarea țevilor în siguranță pe plafonul unui vehicul comercial ușor. CRUZ Pipe Carrier a fost conceput special pentru transportarea profesională pe vehicul a țevilor de cupru și din alte materiale, precum și a conductelor din plastic sau din alt tip de materiale lungi, în siguranță și economic. Suportul pentru țevi este deschis la ambele capete pentru a ușura descărcarea și încărcarea materialului. Închiderile prezintă un sistem de siguranță integrat pentru a împiedica furtul materialului transportat.

SL

Oprema za varen transport cevi na strehi lahkega gospodarskega vozila. Nosilec cevi CRUZ Pipe Carrier je bil posebej zasnovan za profesionalce za varen in ergonomski transport bakrenih cevi in drugih materialov ter plastičnih cevi in drugih vrst dolgih materialov na svojem vozilu. Nosilec cevi ima na obeh koncih odprtino za lažje nalaganje in razkladanje materiala. Zapirala imajo integriran varnostni sistem za preprečevanje kraje prevažanega materiala.

BG

Аксесоар за безопасно транспортиране на тръби на покрива на лекотоварния автомобил. CRUZ Pipe Carrier е разработен специално, за да могат професионалистите да транспортират безопасно и ергономично тръби от мед и други материали, както и проводници от пластмаса и дълги елементи от други материали върху покрива на своето транспортно средство. Носачът за тръби има отвори в двата края за улесняване на товаренето и разтоварването на материала. Заклучващите елементи имат интегрирана система за сигурност за предотвратяване на кражба на транспортирания материал.



certifications

CRUZ product certification & homologation

- TÜV-GS
- CRASH TEST
- ECE R26
- ISO/DIS
- ISO/PAS



CRASH TEST (✓)

ECE R26



DIN 75302:2019
ISO/PAS 11154:2006

CRUZBER company certification

- DIN EN ISO 9001:2015



	■	□	—	✓
pt	incluido	opcional	indisponível	disponível
it	incluso	optional	non disponibile	disponibile
nl	inclusief	optioneel	niet beschikbaar	beschikbaar
gr	περιλαμβάνονται	προαιρετικός	μη διαθέσιμο	διαθέσιμο
tr	Dahil	Opsiyonel	Hazır değil	Hazır
hr	Uključen	Opција	Nije dostupan	Dostupan
ru	входят в комплект	дополнительно	не доступно	доступно
pl	W zestawie	Opcja	Nie dostępny	Dostępny
cz	obsahuje	ize dokoupit	není k dispozici	k dispozici
hu	tartozék	opcionális	nem elérhető	elérhető
ro	inclus	optional	nu este disponibil	disponibil
sl	vkjučeno	opcijsko	ni dobavljivo	dobavljivo
bg	включен	по избор	не е налице	наличен

INDEX ←

support

warranty

www.cruzber.com/gl/en/content/3617-warranty

product registration

www.cruzber.com/gl/en/content/3621-product-registration

contact

aftersales@cruzber.com

+34 957 538 354

social media

www.facebook.com/cruzber

www.twitter.com/cruzber1963

www.youtube.com/cruzber1963

www.instagram.com/cruzber1963



follow us.





www.cruzber.com
roof racks & accessories

CRUZBER SA
Pol. Ind. Las Salinas II, parc. 12
E-14960-Rute (Córdoba) Spain

+34 957 538 354
info@cruzber.com

follow us.

